



CODE OF SAFETY FOR SMALL COMMERCIAL VESSELS

OPERATING IN THE CARIBBEAN

SCV CODE

Prepared
by the

International Maritime Organization

for

Caribbean Countries

May 2010

PREAMBLE

The aim of this Code is to prescribe standards of construction, and emergency equipment for small commercial vessels operating in the Caribbean Region. The regulations are based on the United States Coast Guard Code of Federal Regulations 46 Sub-Chapter T (certification of small passenger vessels) which are regarded as equivalent to IMO Convention requirements for such vessels, Sub-Chapter C (Uninspected vessels) and The United Kingdom Code of Practice for the Safety of Small Workboats and Pilot Boats.

It should be noted that requirements for small commercial vessels of 24 metres and over in length, on international voyages, or those under 24 metres in length which carry more than 150 passengers or provide overnight accommodation for more than 50 passengers, are given in the Code of Safety for Caribbean Cargo Ships and the International Convention on the Safety of Life at Sea, 1974, as amended, (SOLAS) for cargo and passenger ships respectively. Nevertheless, small commercial vessels of 24 metres and over in length engaged on voyages in national waters only, could be allowed to operate under the provisions of this Code by the Administration.

Administrations that are party to SOLAS, who notify IMO that the Code has been determined to be equivalent to the provisions of SOLAS under regulation I/5, for passenger vessels of less than 24 metres in length on international voyages, can issue such vessels with a SOLAS Passenger Ship Safety Certificate along with a copy of the notification of equivalency to IMO.

Model Training Courses for Boatmasters and Boat Engineers are available from the Office of the Regional Maritime Adviser (Caribbean). These courses provide a blueprint for the training of Boatmasters and Boat Engineers and seek to ensure that persons who operate small commercial vessels are competent to carry out their duties efficiently, Contact information is as follows:

Fax: 1-868-625-8666 Office of the Regional Maritime Adviser Telephone: 1-868-624-6159
2nd Floor, ANSA House
Corner Queen & Henry Streets
Trinidad. W.I

Email cpyoung@imo.org
regional.maritime.adviser@gmail.com

This publication contains revisions up to May 2010.

ARRANGEMENT

ARRANGEMENT	II
CHAPTER I - GENERAL PROVISIONS.....	1
<i>Part A - Application and Interpretation.....</i>	<i>1</i>
1 Application.....	1
2 Definitions.....	1
3 Equivalence and exemptions.....	6
4 Approved equipment and material	6
<i>Part B - Inspections</i>	<i>7</i>
5 Extension of Inspection.....	7
6 Notice of inspection deficiencies and requirements.....	7
7 Unsafe practices	7
8 Hull and Tailshaft Examinations.....	7
9 Repairs, Alterations and Modifications.....	7
10 Additional tests and inspections.....	8
<i>Part C - Certification.....</i>	<i>8</i>
11 Application for a Certificate of Inspection.....	8
12 Certificate of Inspection	8
13 Description of Certificate	9
14 Posting of Certificates, Permits and Stability Letters.....	9
15 Special Permits.....	9
<i>Part D - Passenger and Crew Capacity.....</i>	<i>9</i>
16 Total Number of persons permitted	9
<i>PART E - Passenger Ships on International Voyages</i>	<i>10</i>
17 Certification.....	10
18 Safety Management System	10
19 Ship Security System	11
20 Additional Requirements.....	11
CHAPTER II - CONSTRUCTION.....	11
<i>Part A - General Provisions.....</i>	<i>11</i>
1 General Provisions	11
2 Plans and Information to be Submitted	12
3 Hull Structure	12
4 Means of Escape	13
<i>Part B - Watertight and Weathertight Openings.....</i>	<i>13</i>
5 Hatchways.....	13
6 Hatches which are open at sea.....	13
7 Doorways located above the weather deck	14
8 Companion hatch openings	14
9 Skylights.....	14
10 Portlights and Windows	15
11 Ventilators	16
<i>Part C - Accommodation.....</i>	<i>16</i>
12 General	16
13 Crew Spaces	16
14 Passenger Accommodation	17
15 Passenger capacity	17
16 Water services	18
17 Galley	18
18 Toilet facilities	18

19	Stowage facilities for personal effects	19
<i>Part D - Working Decks</i>		19
20	Surface of Working Decks	19
21	Rails and Guards	19
CHAPTER III – FREEBOARD, STABILITY AND WATERTIGHT INTEGRITY		20
<i>Part A - Freeboard</i>		20
1	Minimum Freeboard.....	20
2	Loading Marks	20
3	Loading of a vessel.....	20
<i>Part B - Stability</i>		20
4	Stability Information for Operating Personnel.....	20
5	Stability Information	21
6	Intact stability requirements in general	21
7	Intact stability requirements for a sailing vessel	21
8	Simplified stability proof test procedure and assumptions	22
9	Installation of Ballast	24
10	Open Boats	25
11	Foam flotation material	25
<i>Part C - Watertight Integrity</i>		26
12	Drainage of Weather Decks	26
13	Air Pipes.....	26
14	Sea Inlets and Discharges.....	26
15	Materials for Valves and Associated Piping	27
<i>Part D - Subdivision</i>		27
16	Collision Bulkheads	27
17	Construction and Location of Collision Bulkheads	27
18	Watertight Subdivision Bulkheads.....	28
19	Subdivision of Cargo Vessels	28
20	Subdivision of Passenger Vessels	28
21	Location of Watertight Bulkheads for Subdivision.....	29
CHAPTER IV - MACHINERY.....		32
<i>Part A - General Provisions</i>		32
1	General requirements	32
2.	Gasoline engines for propulsion.....	34
3	Ventilation of Spaces relating to Gasoline	35
4.	Ventilation of spaces relating to diesel.	36
5	Exhausts	37
6	Engine Starting.....	37
7	Portable Plant	38
8	Propulsion Engine Control Systems.....	38
<i>Part B - Steering and Propeller Systems</i>		38
9	Main Steering Gear	38
10	Auxiliary Means of Steering	39
11	Propeller Systems.....	40
<i>Part C - Bilge Systems</i>		41
12	General Provisions for Bilge Systems.....	41
13	Bilge piping system.....	41
14	Bilge pumps	41
15	Bilge high level alarms.....	43
<i>Part D - Electrical Arrangements</i>		44
16	General Provisions	44
17	Power Sources	45
18	Electrical Systems	46

19	Cables and Wiring.....	46
20	Batteries.....	47
21	Battery InstalLation	47
22	General grounding requirements	47
23	Lighting	47
24	Hazardous Spaces.....	48
CHAPTER V - FIRE PROTECTION		49
<i>Part A - General Provisions.....</i>		<i>49</i>
1	Fire Protection Provisions	49
2	Machinery Space - Construction	49
3	Insulation.....	50
4	Cooking Appliances	50
5	Fire Safety	51
<i>Part B - Fire Extinguishing and Detecting Equipment.....</i>		<i>51</i>
6	Equipment installed but not required	51
7	Fire pumps.....	51
8	Fire main and hydrants.....	51
9	Fire hoses and nozzles.....	52
10	Requirement for Fixed Fire Extinguishing and Detecting Systems	52
11	Number, Type and location of Portable Fire Extinguishers	53
12	Fire axe.....	55
13	Fire bucket.....	55
14	Servicing of fixed and portable fire extinguishers	55
15	Fire Blanket.....	55
All ships which have a galley or cooking area shall be provided with a fire blanket which is positioned such that is available for immediate use in the event of a fire in the galley or cooking area.....		55
CHAPTER VI - LIFESAVING EQUIPMENT.....		56
1	General Provisions	56
2	Number and Type of Survival Craft.....	56
3	EPIRB, SART and Radar Reflector	56
4	Distress signals.....	57
5	Lifebuoys.....	57
6	Lifejackets.....	58
7	Stowage of survival craft.....	58
8	Special provisions for buoyant apparatus.....	59
8A	Servicing of life saving appliances.....	60
8B	Repair of inflatable survival craft.....	61
8C	Record of repair and servicing	61
9	Survival craft equipment	61
10	Retro-reflective Material	61
11	Rescue and retrieval of persons from the water.	61
CHAPTER VII - MISCELLANEOUS SYSTEMS AND EQUIPMENT.....		63
1	General Provisions	63
2	Navigation Lights, Shapes and Sound Signals.....	63
3	Charts and Nautical Publications	63
4	Navigation Equipment	63
5	Radio and Signalling Equipment.....	64
6	Public address systems	64
7	Mooring and Ground Tackle	65
8	First Aid Kit	65
9	Cooking and Heating.....	66

10	Pollution Prevention Equipment and Procedures.....	66
CHAPTER VIII - OPERATIONAL REQUIREMENTS.....		68
<i>Part A - Operational Requirements</i>		<i>68</i>
1	General Provisions	68
2	Marine Casualties.....	68
3	Logbook	68
4	Miscellaneous Operating Requirements.....	69
<i>Part B - Preparations for Emergencies</i>		<i>70</i>
5	Record of Passengers	70
6	Passenger Safety.....	70
7	Emergency Instructions.....	71
8	Recommended Emergency Instructions Format	71
9	Emergency Station Bill	73
10	Abandon Ship and Man Overboard Drills and Training	73
11	Fire Fighting Drills and Training	74
13	Markings Required.....	74
14	Operational Readiness, Maintenance and Inspection of Lifesaving Equipment.....	75
15	Instruction manuals, documentation, signs/notices and language used	75
CHAPTER IX - LICENCING OF BOATMASTERS AND ENGINEERS, MANNING AND HOURS OF WORK.....		76
<i>Part A - Licences.....</i>		<i>76</i>
1	Master.....	76
2	Engineers.....	76
2 A	Crew.....	76
3	Licence issue, standards and conditions.....	77
4	Grades and area restrictions of Boatmaster Licences.....	77
5	Requirements for obtaining a Boatmaster Licence	78
6	Practical Instruction	79
7	Examination for Boatmaster Licences	79
8	Grade and Area Restrictions of Boat Engineer Licences	79
9	Requirements for obtaining a Boat Engineer Licence.....	80
10	Approved Course	80
11	Examination for Boat Engineer Licences.....	80
12	Existing licences.....	81
13	Period of Validity and Renewal of Licence	81
14	Medical Fitness Certificate.....	81
15	Record and surrender of licences	82
<i>Part B - Hours of Work.....</i>		<i>82</i>
16	Working Hours.....	82
<i>Part C - Manning.....</i>		<i>83</i>
17	Additional crew	83
ANNEX 1		84
FORM OF CERTIFICATE OF INSPECTION		84
ANNEX 2		87
SIMPLIFIED STABILITY TEST PROCEDURE		87
ANNEX 3		96
SMALL COMMERCIAL VESSEL SIMPLIFIED SUBDIVISION CALCULATION		96
ANNEX 4		101
FIRE TEST FOR FRP		101

ANNEX 5	102
IGNITABILITY TEST FOR COMBUSTIBLE INSULATIONS	102
ANNEX 6	103
RECOMMENDED EMERGENCY BROADCAST INSTRUCTIONS	103
ANNEX 7	104
ANCHORS AND CABLES	104
ANNEX 8	105
FIRST AID KITS	105
ANNEX 9	107
ESTIMATING GUIDELINES FOR HOLDING TANK CAPACITY	107
ANNEX 10	108
FORM OF BOATMASTER AND BOAT ENGINEER LICENCE	108
ANNEX 11	109
SYLLABUS FOR BOATMASTER AND BOAT ENGINEER LICENCES	109

CHAPTER I - GENERAL PROVISIONS

PART A - APPLICATION AND INTERPRETATION

1 Application

1.1 The Code applies to:

- .1 commercial vessels, which are cargo, and passenger vessels of less than 24 metres, but 5 metres or more in length and which carry not more than 150 passengers or provide overnight accommodation for up to 50 passengers; and
- .2 commercial vessels of less than 24 metres in length, measured in accordance with the International Convention on Load Lines, 1966, as amended.

1.2 The Code shall not apply to:

- .1 fishing or pleasure vessels;
- .2 a vessel holding a valid International Passenger Ship Safety Certificate issued under the provisions of the International Convention on the Safety of Life at Sea, 1974, as amended (SOLAS) or Caribbean Cargo Ship Safety Certificate as appropriate;
- .3 a boat forming part of a vessels lifesaving equipment that is used to carry passengers only in emergencies or during emergency exercises; and
- .4 a vessel of a foreign country, who's government has inspection laws approximating those of this Code, which has on board a current valid certificate of inspection or other certificates permitting the carrying of passengers, or cargo in the appropriate sea areas, issued by its Government, unless there are clear grounds for believing that the condition of the vessel or of its equipment does not correspond substantially with the particulars of any of the certificates or is such that the vessel is not fit to proceed to sea without presenting an unreasonable threat to the safety of the vessel or its crew and passengers or the environment.
- .5 small commercial vessels which carry 12 or less passengers and hold a valid certificate issued under the provisions of a Code specially designed for such vessels. However a Certificate of Compliance with the provisions of the SCV Code should be attached to the Certificate required by the Code to which such vessels were surveyed.

1.3 Unless otherwise specified the Code applies to both new and existing vessels.

2 Definitions

For the purpose of the Code, unless expressly provided otherwise -

- .1 *Accommodation space* means any space other than machinery spaces, control spaces and storerooms, used or accessible by passengers or crew including, but not limited to:

- Hall;
- Dining room and messroom;
- Lounge or cafe;
- Public sales room;
- Overnight accommodation space;
- Barber shop or beauty parlour;

Office or conference room;
 Washroom or toilet space;
 Medical treatment room or dispensary; or
 Game or hobby room.

.2 *Administration* means the Maritime Administration of a Country.

.3 *Beam or B* means the maximum width of a vessel measured from:

On wooden vessels from the outside of planking on one side to the outside of planking on the other; and

On all other vessels from the outside of a frame on one side to the to outside of a frame on the other

.4 *Bulbous bow* means a design of bow in which the forward underwater frames ahead of the forward perpendicular are swelled out at the forefoot into a bulbous formation.

.5 *Bulkhead deck* means the uppermost deck to which watertight bulkheads and the watertight shell extends.

.6 *Cargo space* means a:

Cargo hold;
 Refrigerated cargo space; or
 A trunk leading to or from a space listed above.

.7 *Coastal waters* means an area designated as such by the Administration and where this is not so designated it means an area not more than 20 miles from a safe refuge.

.8 *Cockpit vessel* means a vessel with an exposed recess in the weather deck extending not more than one-half of the length of the vessel measured over the weather deck.

.9 *Commercial vessel* means a vessel in commercial use and includes passenger vessels but does not include a fishing vessel.

.10 *Crew* includes every person, except masters and pilots, employed or engaged in any capacity on board a vessel;

.11 *Crew accommodation space* means an accommodation space designated for the use of crew members and which passengers are normally not allowed to occupy.

.12 *Draft* means the vertical distance from the moulded baseline of a vessel at mid length to the waterline.

.13 *Employer*, in relation to a master who has command of a vessel in the course of his employment, means the person who employs that master in that employment;

.14 *Existing vessel* means a vessel that is not a new vessel or a vessel for which initial construction has begun before [1July 2002].

.15 *Exposed waters* is a term used in connection with stability criteria and means any waters that are more than 20 nautical miles from a harbour or safe refuge, or those waters which are less than 20 nautical miles from a harbour or safe refuge and which are not designated coastal or protected waters.

- .16** *Ferry* means a vessel that:
operates only in protected waters
has provisions only for deck passengers or vehicles, or both; and
operates on a short run on a scheduled service between two or more places.
- .17** *Fishing vessel* means a vessel used or intended to be used for fishing for profit and does not include vessels used for the carriage of passengers used for sport fishing.
- .18** *Flash point* means the temperature at which a liquid gives off a flammable vapour when heated using the Pensky-Martens Closed Cup Tester method.
- .19** *Float-free launching or arrangement* means that method of launching a survival craft whereby the survival craft is automatically released and break free from a sinking vessel in such a manner as to be ready for use by survivors.
- .20** *Flush deck vessel* means a vessel with a continuous weather deck located at the uppermost sheer line of the hull.
- .20A** *Galley* means a space containing appliances with cooking surfaces that may exceed 120°C (250°F).
- .21** *Gross or net tonnage* is the measurement of a vessel as determined by the Administration.
- .22** *Harbour or safe refuge* means a port, inlet or other body of water normally sheltered from heavy seas by land and in which a vessel can navigate and safely moor. The suitability of a location as a harbour or safe refuge is as determined by the Administration.
- .23** *Inflatable survival craft* or *Inflatable lifejacket* means one which depends upon non-rigid, gas-filled chambers for buoyancy and which are normally kept deflated until ready for use.
- .24** *IMDG Code* means the International Maritime Dangerous Goods Code published by the International Maritime Organization.
- .25** *International voyage* means a voyage between one country and a port outside that country.
- .26** *Launching appliance* means a device for transferring a survival craft, rescue boat or boat for the recovery of a man overboard from its stowed position safely to the water. For a launching appliance using a davit, the term includes davit, winch and falls.
- .27** *Length* means length overall, the distance between the foreside of the foremost fixed permanent structure and the after side of the aftermost permanent structure.
- .28** *LSA Code* means the International Life-Saving Appliance (LSA) Code adopted by the Maritime Safety Committee of the International Maritime Organization at its sixty-sixth session by Resolution MSC.48 (66) as amended
- .29** *Machinery space* means a space including a trunk, alleyway, stairway or duct to such a space that contains:

propulsion machinery of any type;
 steam or internal combustion machinery;
 oil transfer equipment;
 electrical motors of more than 7.5 kW (10 hp);
 cargo refrigeration equipment;
 one or more oil-fired boilers or heaters; or
 electrical generating machinery.

.30 *Major conversion* means repairs, alterations or modifications that: -

- (a) substantially alter the dimensions of a vessel;
- (b) substantially increase a vessel's service life; or
- (c) alter the functional aspects of a vessel

.31 *Master* means the individual having command of a commercial vessel.

.32 *Means of escape* means a continuous and unobstructed route from any point in a vessel to an embarkation station. A means of escape can be both vertical and horizontal, and may include doorways, passageways, stair towers and public spaces. Cargo spaces, machinery spaces, rest rooms, hazardous areas, escalators and elevators shall not form any part of a means of escape.

.33 *New vessel* means a vessel for which the initial construction began on or after [1 July 2002] or a vessel, which has undergone repairs, alterations or modifications of a major character, as identified in I/9.4 on or after this date.

.34 *Non-self-propelled vessel* means a vessel, which does not have a means of propulsion installed, such as propulsive machinery, masts, spars or sails.

.35 *Open boat* means a vessel which is open to the elements and is not fitted with a complete watertight or weathertight deck or complete structure above the waterline.

.36 *Operating station* means the principal steering station on the vessel from which the individual on duty normally navigates the vessel.

.37 *Overnight accommodation or overnight accommodation space* means an accommodation space for use by passengers or by crew members which has one or more berths, including beds or bunks, for passengers or crew members to rest for extended periods. Overnight accommodations do not include spaces, which contain only seats, including reclining seats.

.38 *Passenger* means any person carried in a vessel except a person employed or engaged in any capacity on board the vessel or a child under one year of age.

.39 *Passenger vessel* means a vessel other than a pleasure vessel carrying more than 12 passengers, and includes a vessel that is provided for the transport or entertainment of lodgers at any institution, hotel, boarding house, guest house or other establishment.

.40 *Piping system* includes piping, associated fittings and valves.

.41 *Pleasure vessel* means-

- .1 (a) any vessel which at the time it is being used is-

- (i) in the case of a vessel wholly owned by an individual or individuals, used only for the sport or pleasure of the owner or the immediate family or friends of the owner; or
 - (ii) in the case of a vessel owned by a body corporate, one on which the persons are employees, officers or shareholders of the body corporate, or their immediate family or friends; and
- (b) on a voyage or excursion which is one for which the owner does not receive money for or in connection with operating the vessel or carrying any person, other than as a contribution to the direct expenses of the operation of the vessel incurred during the voyage or excursion; or

.2 any vessel wholly owned by or on behalf of a club formed for the purpose of sport or pleasure which, at the time it is being used, is used only for the sport or pleasure of members of the club or their immediate family, and for the use of which any charges levied are paid into club funds and applied for the general use of the club; and

.3 in the case of any vessel referred to in paragraphs (1) or (2), no other payments are made by or on behalf of the users of the vessel, other than by the owner;

and in this definition, “immediate family” means, in relation to an individual, the husband or wife of the individual, and a relative of the individual or the relative’s husband or wife, “relative” means brother, sister, ancestor or lineal descendant, and “owner” includes charterer.

.42 *Protected waters* means an area of sheltered waters presenting no special hazards such as most rivers, harbours and lakes, designated by the Administration for the operation of small vessels and where not so designated means an area not more than 3 miles from a safe haven.

.43 *Survival craft* means a lifeboat, liferaft, buoyant apparatus or small boat carried aboard a vessel.

.44 *Vessel* includes any ship or boat or any other description of vessel capable of being navigated.

.45 *Voyage* includes an excursion.

.46 *Watertight* means designed and constructed to prevent the passage of water in any direction.

.47 *Weathertight* means that in any sea conditions water will not penetrate into the vessel.

.48 *Well deck vessel* means a vessel with a weather deck fitted with solid bulwarks that impede the drainage of water over the sides or a vessel with an exposed recess in the weather deck extending more than one-half of the length of the vessel measured over the weather deck.

.49 *Working day*, in relation to any person to whom Chapter IX of this Code applies means any period during which the person is on duty which is not followed by an interval for rest of not less than 8 hours.

.50 *Workspace* means a space, not normally occupied by a passenger, in which a crew member performs work and includes, but is not limited to, a galley, operating station or machinery space.

3 Equivalence and exemptions

3.1 Where the Code requires that a particular fitting, material, appliance or apparatus, or type thereof, piece of equipment or machinery shall be fitted or carried in a vessel, or that any particular provision shall be made, the Administration may permit any other fitting, material, appliance or apparatus or type thereof, piece of equipment or machinery to be fitted or carried or other provision to be made in that vessel where it is satisfied by trials or otherwise that the alternative is at least as effective as that required by the Code.

3.2 The Administration may exempt any vessel or description of vessels from all or any of the provisions of the Code, as shall be specified in the exemption, provided that the Administration is satisfied that compliance with such provision is either impracticable or unreasonable in the case of that vessel or description of vessels. The exemption may be issued on such terms, if any, as the Administration may specify and subject to giving reasonable notice, alter or cancel any such exemption.

4 Approved equipment and material

Equipment and material that is required by the Code to be approved or of an approved type shall have been manufactured and approved in accordance with the design and testing requirements of the Administration. In construing the term "*to the satisfaction of the Administration*" in relation to standards for type approval these shall be equivalent to those of the Canadian Coast Guard (CCG), European Economic Community (EEC), the United States Coast Guard (USCG), the International Maritime Organization (IMO) or an organization recognized to perform statutory work on behalf of the Administration in terms of certification and survey functions connected with the issuance of international certificates.

PART B - INSPECTIONS

5 Extension of Inspection

5.1 Inspections for certification are based on the information, specifications, drawings and calculations available to the Administration.

5.2 The initial or renewal inspection will cover the following items: hull, machinery, electrical equipment, lifesaving equipment, fire protection equipment, pressure vessels and boilers, steering systems, miscellaneous equipment and systems, sanitation and operational practices including the competence and composition of the crew.

5.3 In general, the scope of an annual inspection is the same as for the inspection for issue of a certificate of inspection but in less detail.

6 Notice of inspection deficiencies and requirements

During the inspection of a vessel, the marine surveyor will record any deficiencies. The surveyor will provide a copy of these to the owner and discuss arrangements for rectification.

7 Unsafe practices

During the course of any inspection due regard shall be given to confirming that all unsafe practices identified on board have been corrected. Examples of this include fire hazards by virtue of oily residues, unguarded machinery and provision of any protective clothing or devices necessary for the safety of the crew

8 Hull and Tailshaft Examinations

8.1 A thorough examination of the hull, tailshaft, rudders and propellers shall be carried out at the initial and renewal surveys, at the third annual survey and at the discretion of the Administration.

8.2 A passenger vessel certified for operation in exposed waters shall undergo a thorough examination of the hull and tailshaft annually.

8.3 Hull and tailshaft examinations shall include all fittings, fixtures and penetrations of the hull and strengthening arrangements.

9 Repairs, Alterations and Modifications

9.1 Repairs or alterations to the hull, machinery or equipment, which affect the safety of the vessel shall not be made without the approval of the Administration, except in an emergency. Drawings or written specifications of proposed alterations should be submitted to the Administration which may require that an inspection and test be carried out.

9.2 Safe working practices shall be observed in the planning and execution of any alterations, repairs or other operations involving riveting, welding, burning or other fire producing actions aboard a vessel particularly where these take place adjacent to fuel tanks or apparatus connected to the fuel tanks.

9.3 Repairs, alterations and modifications of a major character and outfitting related thereto on existing vessels shall meet the requirements prescribed for a new vessel to such extent as the Administration deems reasonable and practicable. The owner shall inform the Administration of the proposed alterations and modifications before such alterations and modifications are carried out.

9.4 For the purpose of the Code, the following repairs, alterations and modifications shall be recognized as being of "major character":

- (a) any changes that substantially alter the dimensions of the vessel;
- (b) any changes that substantially increase a vessel's service life; or
- (c) any conversions that alter the functional aspects of the vessel.

10 Additional tests and inspections

The Administration may make inspections or tests of the vessel in addition to those described above, as deemed necessary to determine that the vessel and its equipment are suitable for the service in which they are to be employed.

10 A Maintenance of conditions after inspection

- 10.A.1 The condition of the vessel and its equipment shall be maintained to conform with the provisions of the Code to ensure that the vessel in all respects will remain fit to proceed to sea without damage to the vessels or persons on board.
- 10.A.2 After any inspection of a vessel under **I/12** has been completed, no change shall be made in the structural arrangements, machinery or other items covered by the survey without the approval of the Administration.
- 10.A.3 Whenever an accident occurs to a vessel or a deficit is discovered which affects the safety of the vessel or the efficiency or completeness of its life saving appliances or other equipment, the master or owner of the vessel shall report it at the earliest opportunity to the Administration, who shall determine if an inspection under I/12 is necessary.

PART C - CERTIFICATION

11 Application for a Certificate of Inspection

A Certificate of Inspection may be obtained or renewed by making an application in writing to the Administration. The application for inspection of a vessel being newly constructed or converted shall be submitted prior to the start of the construction or conversion.

12 Certificate of Inspection

12.1 A vessel to which the Code applies shall not be operated without having on board a valid Certificate of Inspection issued by the Administration following a satisfactory inspection. The form of the certificate is given in **Annex 1**. This certificate shall remain valid for a period not exceeding 1 year for vessels carrying more than 12 passengers on international voyages and 5 years for all other vessels from the date of inspection provided that the vessel successfully completes an annual inspection or unless revoked by the Administration.

12.2.1 The inspection for the renewal of the certificate shall be conducted up to 2 months prior to the expiry of the Certificate of Inspection. Where a vessel is inspected not more than 30 days before the date of expiry of a Certificate of Inspection, the new certificate shall be dated from the expiry date.

12.2.2 The annual inspection shall be conducted between the 10th to 14th month of the anniversary date of the issuance of the Certificate of Inspection.

12.3 Every vessel to which a Certificate of Inspection has been issued shall conform to these

regulations and any additional measures deemed appropriate by the Administration throughout the period of validity of the certificate.

12.4 Where necessary to prevent delay of the vessel, a temporary Certificate of Inspection may be issued pending the issuance and delivery of the regular Certificate of Inspection and shall be carried in the same manner as the regular certificate.

13 Description of Certificate

The Certificate of Inspection issued to a vessel shall describe:

- the vessel,
- the date of inspection and expiry of the certificate,
- the issuing authority,
- the operating area specified under headings "*Protected waters*", "*Coastal waters*" or "*Exposed Waters*".
- the minimum manning requirements,
- the fire detection and extinguishing equipment required
- the life saving appliances to be carried
- the maximum number of passengers and total persons that shall be carried,
- the number of passengers the vessel may carry in overnight accommodation spaces,
- the name of the owner and managing operator,
- any equivalencies or exemptions accepted or authorised by the Administration,
- any other such conditions of operation as may be determined by the Administration.

14 Posting of Certificates, Permits and Stability Letters

The Certificate of Inspection or any stability letters, shall be posted under glass or other suitable transparent material, such that all pages are visible, in a conspicuous place on the vessel where observation by passengers is likely. Where posting is impracticable, the certificates shall be kept on board in a weathertight container readily available for use by the crew to display to passengers and others on request.

15 Special Permits

15.1 Where a vessel does not hold a valid Certificate of Inspection, the Administration may permit the vessel to proceed without passengers to another port for repairs, under such conditions as may be considered necessary. Application for such permission should be made in writing to the Administration.

15.2 The Administration, in exceptional circumstances, may permit a vessel to engage in a voyage with a greater number of persons or on a more extended route, or both, than permitted by its Certificate of Inspection where it is satisfied that the operation can be undertaken safely.

PART D – PASSENGER AND CREW CAPACITY

16 Total Number of persons permitted

16.1 The total numbers of persons permitted to be carried on a vessel shall be determined by the Administration.

16.2 In determining the total number of persons permitted to be carried the Administration shall take into account the applicable stability restrictions and subdivision requirements in **Chapter III**, the vessel's operating area, general arrangement, means of escape, lifesaving equipment, and minimum

manning requirements and the maximum number of passengers permitted in accordance with **II/15.1** and **II/15.2**.

16.3 The total number of persons permitted to be carried should not exceed the total number of persons calculated to be on board when the vessel successfully completed the stability requirements of regulation **III/8**.

PART E - PASSENGER SHIPS ON INTERNATIONAL VOYAGES

17 Certification

17.1 Administrations that are party to SOLAS, who notify IMO that the Code has been determined to be equivalent to the provisions of SOLAS under regulation I/5, for passenger vessels of less than 24 metres in length on international voyages, may issue such vessels with a SOLAS Passenger Ship Safety Certificate along with a copy of the notification of equivalency to IMO.

17.2 Vessels issued with a SOLAS Passenger Ship Safety Certificate in accordance with regulation **I/17.1** shall also comply with the requirements of regulations **I/18** and **19** for the issue of a Document of Compliance and Safety Management Certificate, and a Ship Security Certificate respectively and with regulation **I/20**.

18 Safety Management System*

18.1 The owner of a passenger vessel engaged on international voyages, or any other organization or person such as the manager or the bareboat charterer who has assumed responsibility for the operation of the ship from the owner, and the vessel shall comply with the requirements of:

- .1 Chapter IX of the International Convention for the Safety of Life at Sea (SOLAS) 1974 as amended; and
- .2 the International Safety Management Code for the Safe Operation of Ships and Pollution Prevention, adopted in London on 24 May 1994.

18.2.1 A Document of Compliance shall be issued to every company which complies with the requirements of the International Safety Management Code. This document shall be issued by the Administration, by an organization recognized by the Administration, or at the request of the Administration by another Contracting Government to SOLAS.

18.2.2 A copy of the Document of Compliance shall be kept onboard the ship in order that the master can produce it on request for verification.

18.2.3 A Certificate, called a Safety Management Certificate, shall be issued to every ship by the Administration or an organization recognized by the Administration. The Administration or organization recognized by it shall, before issuing the Safety Management Certificate, verify that the company and its shipboard management operate in accordance with the approved safety-management system.

18.3 The safety-management system shall be maintained in accordance with the provisions of the International Safety Management Code.

* The United States Coast Guard has developed a simple Draft Safety Management System which can be used as a guide to put in place a safety management system that complies with the requirements of the ISM Code. This Draft System is available on request.

19 Ship Security System

19.1 The owner of a passenger vessel engaged on international voyages, or any other organization or person such as the manager or the bareboat charterer who has assumed responsibility for the operation of the ship from the owner, and the vessel shall comply with the requirements of:

- .1 Chapter XI-2 of the International Convention for the Safety of Life at Sea (SOLAS) 1974 as amended; and
- .2 the International Ship and Port Facility Security Code for the Security of Ships and of Port Facilities, adopted in London on 12 December 2002.

19.2 A Certificate, called an International ship Security Certificate, shall be issued to every ship by the Administration or an organization recognized by the Administration. The Administration or organization recognized by it shall, before issuing the Ship Security Certificate, verify that the ship's security system and any associated equipment fully complies with Chapter XI-2 and Part A of the Code, is in satisfactory condition and fit for the serve for which the ship is intended.

19.3 The ship security system shall be maintained in accordance with the provisions of the International Ship and Port Facility Security Code.

20 Additional Requirements

20.1 Passenger Ships on international voyages and issued with a SOLAS Passenger Ship Safety Certificate shall in addition to the requirements of the SCV Code, comply with the requirements of the following:

- .1 Regulation V/19.2.4 of the International Convention for the Safety of Life at Sea (SOLAS) 1974 as amended; and
- .2 Regulations 3 and 5 of Chapter XI-1 of the International Convention for the Safety of Life at Sea (SOLAS) 1974 as amended.

CHAPTER II - CONSTRUCTION

PART A - GENERAL PROVISIONS

1 General Provisions

1.1 The construction and arrangement of a vessel shall allow the safe operation of the vessel in accordance with the terms of its Certificate of Inspection giving consideration to:

provisions for a seaworthy hull,
 protection against fire,
 means of escape from all spaces likely to be occupied by passengers or crew,
 guards and rails in hazardous places,
 ventilation of enclosed spaces,
 necessary facilities for the accommodation and use of passengers and crew.

The Administration shall arrange for the phasing in of the provisions of this Chapter to existing vessels within 3 years of the coming into force of the Code .

1.2 Unless authorized by the Administration, a vessel certified for operation in exposed waters shall be fitted with a watertight weather deck over the length of the vessel and be of adequate

structural strength to withstand the sea and weather conditions likely to be encountered in the area of operation. The vessel shall be so constructed as to meet the appropriate requirements of Chapter III.

2 Plans and Information to be Submitted

2.1 The owner of a vessel requesting initial inspection for certification shall, prior to the start of construction unless otherwise allowed by the Administration, submit for approval to the Administration, at least two copies of plans concerning the following areas: machinery installation including piping systems; electrical installation; arrangement in detail of lifesaving equipment; arrangement in detail of fire equipment, mast and rigging arrangements; navigation lights; steering and control equipment; and sanitation arrangements.

2.2 For a vessel of not more than 20 m (65 feet) in length, the owner may submit specifications, sketches, photographs, line drawings or written descriptions instead of any of the required drawings, provided the required information is adequately detailed and acceptable to the Administration.

2.3 The provisions of **II/ 2.1** and **II/2.2** apply equally to existing vessels

3 Hull Structure

3.1.1 Except as provided in **II/3.2** a vessel shall comply with the applicable design requirements of one of the Rules and Regulations of a member of the International Association of Classification Societies (IACS).*

3.1.2 Inflatable or rigid vessels shall meet the design and construction requirements of Chapter III of SOLAS and the parts of the LSA Code which are appropriate to the type of vessel.

3.1.3 Vessels built to other standards shall be considered specifically by the Administration.

3.2 An existing vessel shall be considered to be of acceptable construction where it is

- .1** built to one of the standards described in **II/3.1**; or
- .2** of a design with a record of at least five years' history of safe operation in an area where the sea and weather conditions and manner of use are no less severe than those likely to be encountered in the area of operation.

3.3 The design, materials, and construction of masts, posts, yards, booms, bowsprits, and standing

* Details of IACS members can be found at www.IACS.org.uk

Applicable standards for the material and construction of the vessel include the following:

- .1** Wooden hull vessels – Rules and Regulations for the Classification of Yachts and Small Craft, Lloyd's Register of Shipping (LR).
- .2** Steel hull vessels - and Regulations for the Classification of Special Service craft, LR; or Rules for Building and Classing Steel Vessels under 90 ms (200feet) in length, American Bureau of shipping (ABS).
- .3** Glass fibre reinforced plastic vessels - Rules and Regulations for the Classification of Special Service Craft, LR; or Rules for Building and Classing Reinforced Plastic Vessels, ABS.
- .4** Aluminum hull vessels- Rules and Regulations for the Classification of Special Service Craft, LR. Rules for Building and Classing Aluminum vessels ABS.

rigging on a sailing vessel should be suitable for the intended service. The hull structure should be adequately reinforced to ensure sufficient strength and resistance to plate buckling.

4 Means of Escape

4.1 Each space of more than 3.7 m (12 feet) in length accessible to passengers or used by the crew on a regular basis shall have at least two means of escape, one of which shall not be a watertight door.

4.2 The two required means of escape shall be widely separated and, where possible, at opposite ends or sides of the space to minimise the possibility of one incident blocking both escapes. Means of escape may include normal exits and emergency exits, passageways, stairways, ladders, deck scuttles, and windows. The number and dimensions of the means of escape from each space shall be sufficient for rapid evacuation in an emergency of the maximum number of persons likely to occupy the space under any operational conditions. The size of the escapes shall be to the satisfaction of the Administration.

4.3 In a passenger vessel, the sum of the width of all doors and passageways used as means of escape from a space shall not be less than 8.4 m (27.6 feet) multiplied by the number of passengers for which the space is designed with a minimum clear opening of not less than 810mm (32 inches). In all vessels, doors or passageways used solely by crew members shall have a clear opening not less than 710 mm (28 inches).

4.4 When a deck scuttle serves as a means of escape, it must not be less than 455 mm (18 inches) in diameter and must be fitted with a quick acting release and a holdback device to hold the scuttle in an open position.

PART B - WATERTIGHT AND WEATHERTIGHT OPENINGS

5 Hatchways

5.1 A hatchway, which gives access to spaces below the weather deck shall be of effective construction and be provided with efficient means of weathertight closure.

5.2 A cover to a hatchway shall be hinged, sliding, or permanently secured by other equivalent means to the structure of the vessel and be provided with sufficient locking devices to enable it to be positively secured in both the open and closed positions.

5.3 A hatchway with a hinged cover which is located in the forward portion of the vessel shall normally have the hinges fitted to the forward side of the hatch, as protection of the opening from boarding sea.

5.4 Hatches, which are identified as forming part of a means of escape shall be capable of being opened from both sides.

5.5 Hatches, which are required to be kept closed for safety reasons when the vessel is at sea shall have prominent “*keep closed*” warning notices attached to the vessel structure on both sides.

6 Hatches which are open at sea

6.1 Where operational needs exist for specified hatches to be open at sea for lengthy periods, these hatches shall be:-

- .1** kept as small as practicable, but never more than 1m² in plane area at the top of the

coaming;

- .2 located at the centre line of the vessel or as close thereto as practicable and compatible with the proper working of the vessel; and
- .3 fitted such that the access opening is at least 300mm (12 inches) above the top of the adjacent weather deck at the side of the vessel.

6.2 Spaces fitted with hatches which are open at sea for lengthy periods shall be provided with means for pumping out the affected space.

7 Doorways located above the weather deck

7.1 A doorway opening onto the weather deck which, gives access to spaces below shall be provided with a weathertight door. The door shall be of efficient construction, permanently attached to the bulkhead, not open inwards, and sized such that the door overlaps the clear opening on all sides, and has efficient means of closure which can be operated from both sides. It shall be of equivalent strength to the structure in which it is fitted.

7.2 A doorway shall be located as close as practicable to the centre line of the vessel. However, where hinged and located in the side of a deckhouse, the door shall be hinged on the forward edge.

7.3 A doorway, which is either forward or side facing, shall be provided with a coaming, the top of which is at least 150mm (6 inches) above the weather deck. A coaming may be portable provided it is permanently secured to the structure of the vessel and can be locked in position.

8 Companion hatch openings

8.1 A companion hatch opening from a cockpit or recess, which gives access to spaces below the weather deck shall be fitted with a coaming, the top of which is at least 300mm (12 inches) above the sole of the cockpit or recess.

8.2 When washboards are used to close a vertical opening they shall be so arranged and fitted that they will not become accidentally dislodged.

8.3 The breadth of the opening of a companion hatch shall not exceed 1 m (39 inches).

9 Skylights

9.1 A skylight on the weather deck, which gives access to spaces below, shall be fitted with a coaming, the top of which is at least 150mm (6 inches) above the deck.

9.2 A skylight shall be of efficient weathertight construction and shall be located on the centre line of the vessel, or as near thereto as practicable. It may be further offset where necessary to provide a means of escape from a compartment below deck.

9.2 When a skylight is an opening type, it shall be provided with efficient means whereby it can be secured in the closed position from both sides.

9.3 In a new vessel, a skylight, which is provided as a means of escape shall be capable of being opened from both sides.

9.4 Unless the glazing material and its method of fixing in the frame is equivalent in strength to that required for the structure in which it is fitted, a portable “blank” shall be provided which can be efficiently secured in place in event of breakage of the glazing. The blank shall be permanently

located close to the skylight that it serves and shall be of suitable material and strength to the satisfaction of the Administration.

10 Portlights and Windows

10.1 A portlight or window shall be fitted in a position so that its sill is not less than 610mm (24 inches) above the load waterline.

10.2 A portlight or window to a space below the weather deck or in a step, recess, raised deck structure, deckhouse or superstructure protecting openings leading below the weather deck shall be constructed to provide weathertight integrity, and be of strength compatible with size of the portlight or window, and the intended area of operation of the vessel. Glass and other glazing material used in windows shall be of a material that will not break into dangerous fragments if fractured.

10.3 Each window, port hole and its means of attachment to the hull or deck house shall be capable of withstanding the maximum load from wave and wind conditions expected due to its location on the vessel and the authorised operating area of the vessel.

10.4 In a new vessel, a portlight or window shall not be fitted in the main hull below the weather deck, unless the glazing material and its method of fixing in the frame are equivalent in strength to that required for the structure in which it is fitted.

10.5 In a new vessel, an opening portlight shall not be provided to a space situated below the weather deck.

10.6 In a new vessel or in an existing vessel where a portlight or window is replaced, portlights, windows and their frames shall meet the requirements of ISO 12216 - Windows, portlights, hatches, deadlights and doors - strength and tightness requirements, or equivalent standard. This standard is recommended for existing vessels.

10.7 In an existing vessel certified for operation in exposed waters, a portlight, fitted below the weather deck and not provided with an attached deadlight shall be provided with a “*blank*”, the number of blanks, shall be sufficient for at least half of the number of such portlights of each different size in the vessel, which can be efficiently secured in place in the event of breakage of the portlight. The blank shall be of suitable material and strength to the satisfaction of the Administration. Such a “*blank*” is not required for a non-opening portlight, which satisfies the requirements of **II/10.3**.

10.8 An opening portlight shall not exceed 250mm (10 inches) in diameter or equivalent area.

10.9 In an existing vessel classed for operation in exposed waters, a window fitted in the main hull below the weather deck, shall meet the requirements of **II/10.3**, or be provided with a blank meeting the requirements of **II/10.7**.

10.10 For the wheelhouse:-

- .1** Windows and other openings at the operating station shall be of sufficient size and properly located to provide an adequate view for safe navigation in all operating conditions;
- .2** windows and their frames shall meet the requirements of ISO 12216 (see **II/10.6**) or equivalent standard, having due regard to the increased thickness of windows comprising one or more laminations in order to achieve equivalent strength;
- .3** polarised or tinted glass shall not be used in windows provided for navigational visibility, although portable tinted screens may be provided for these windows; and

- .4 when a vessel is expected to operate in severe weather, relative to the size of the vessel, efficient storm shutters shall be provided for all front and side facing windows.

11 Ventilators

11.1 A ventilator shall be of efficient construction and be provided with a permanently attached means of weathertight closure.

11.2 A ventilator shall be kept as far inboard as practicable and the height above the deck of the ventilator opening shall be sufficient to prevent the admission of water when the vessel is heeled.

11.3 The Administration may permit the fitting of a ventilator which must be kept open, e.g. for the supply of air to machinery or for the discharge of noxious or flammable gases, provided that it is demonstrated with reference **II/11.2** that downflooding will not occur via the ventilator in any foreseeable situation.

PART C - ACCOMMODATION

12 General

12.1 There shall be sufficient hand holds and grab-rails within the accommodation to allow safe movement around the accommodation when the vessel is in a seaway.

12.2 Heavy items of equipment such as batteries, cooking appliances, etc., shall be securely fastened in place to prevent movement due to severe motions of the vessel. Stowage lockers containing heavy items shall have lids or doors with secure fastening.

12.3 Means of escape from accommodation spaces shall satisfy the requirements of regulation **II/4**, **II/9.2** and **II/9.3**.

12.4 Effective means of ventilation shall be provided to enclosed spaces which may be entered by persons on board.

12.5 An adequate standard of accommodation for all on board shall be provided particularly in vessels intended to be at sea for more than 24 hours,. In providing such accommodation, primary concern shall be directed towards ensuring the health and safety aspects of persons e.g. the ventilation, lighting, water services, galley services, access and escape arrangements.

12.6 On vessels which carry berthed persons below deck, mechanical ventilation shall be provided to accommodation spaces, which are situated completely below the level of the weather deck, excluding any coach roof. As far as practicable, such ventilation arrangements shall be designed to provide at least 6 changes of air per hour when the access openings to the spaces are closed and have an emergency shut down switch located outside of the space for use in case of fire.

13 Crew Spaces

13.1 Crew accommodation spaces and work spaces shall be of sufficient size, adequate construction, and with suitable equipment to provide for the safe operation of the vessel and the protection and accommodation of the crew in a manner practicable for the size, facilities, service, route, speed and modes of operation of the vessel. The deck above a crew accommodation space shall be located above the deepest load waterline.

13.2 Sleeping accommodation shall be provided for all crewmembers of the vessel where it is operated for more than 12 hours in a 24-hour period, unless the crew is put ashore and the vessel is provided with a new crew including the Master.

13.3 Sleeping accommodation shall consist of a bunk or cot for each crewmember and at least 50% of these shall be provided with lee boards or lee cloths.

14 Passenger Accommodation

14.1 All passenger accommodation shall be arranged and equipped to provide for the safety of the passengers in consideration of the route, modes of operation and speed of the vessel.

14.2 The height of deckheads in a passenger accommodation space shall be at least 1.9 m (74 inches) but may be reduced at the sides of a space to allow for camber, wiring, ventilation ducts and piping. The space shall be maintained to minimise fire and safety hazards and to preserve sanitary conditions. Aisles shall be kept clear of obstructions.

14.3 A berth to the satisfaction of the Administration shall be provided for each passenger to be carried in overnight accommodation spaces, save that for voyages not exceeding 24 hours a reclining chair may be provided in lieu of a berth.

14.4 A seat shall be provided for each passenger permitted in a space for which the fixed seating criterion in **II/15.2.3** has been used to determine the number of passengers permitted. A seat shall be constructed to minimise the possibility of injury and avoid trapping occupants. Installation of seats shall provide for ready escape. Seats, including fixed, temporary or portable seats, shall be arranged as follows:

- .1** An aisle of not more than 3.8 m (15 feet) in overall length shall be not less than 610mm (24 inches) in width;
- .2** An aisle of more than 3.8m (15 feet) in overall length shall not be less than 760mm (30 inches) in width;
- .3** Where seats are in rows, the distance from seat front to seat front shall not be less than 760mm (30 inches) and the seats shall be secured to a deck or bulkhead;

14.5 Seats identified in the determination of the maximum number of passengers permitted shall be secured to the deck, bulkhead or bulwark by effective permanent or temporary means.

15 Passenger capacity

15.1 The maximum number of passengers permitted in any passenger vessel shall be the greatest number permitted by any of the following criteria or combination of these criteria.

- .1** Length of Rail - one passenger may be permitted for each 760mm (30 inches) of rail space available to the passengers at the periphery of the deck, not including rail space in congested areas, on stairways and where persons standing in the space would block the vision of the vessel's operators.
- .2** Deck Area - one passenger may be permitted for each square metre (10 square feet) of free deck area available for the passengers' use. Free deck area does not include:

Concession stands, fixed tables, fixed gambling equipment and similar furnishings;
Toilets and washrooms;

Companionways and stairways;
 Spaces occupied and necessary for handling lifesaving equipment or line handling gear or in way of sail booms or running riggings;
 Spaces below deck which are unsuitable for passengers or which would not normally be used by passengers;
 Interior passageways less than 760 mm (30 inches) wide and passageways on open deck less than 460 mm (18 inches) wide;
 Bow pulpits, swimming platforms and areas which do not have a solid deck, such as netting on multi-hull vessels;
 Deck areas in way of paddle wheels; and
 Aisle area.

- .3** Fixed Seating - one passenger may be permitted for each 460mm (18 inches) of width of fixed seating provided. (See **II/14.4**)

15.2 Different passenger capacity criteria may be used on each deck of a vessel and added together to determine the maximum number of passengers to be carried on that vessel. Where seats are provided on part of a deck and not on another, the number of passengers permitted on a vessel may be the sum of the number permitted by the seating criterion for the space having seats and the number permitted by the deck area criterion for the space having no seats. The length of rail criterion may not be combined with either the deck area criterion or the fixed seating criterion when determining the maximum number of passengers permitted on an individual deck.

15.3 The Administration may give special consideration to increasing the passenger allowances for a vessel operating on short runs on protected waters, such as a ferry.

16 Water services

16.1 An adequate supply of fresh drinking water shall be provided and piped to convenient positions throughout the accommodation spaces.

16.2 In addition, an emergency (dedicated reserve) supply of drinking water shall be carried at the rate of 2 litres per person on board.

17 Galley

17.1 A galley shall be fitted with a means for cooking and means for washing food and utensils, and have adequate working surfaces for the preparation of food. The floor shall have a non-ship surface.

17.2 When a cooking appliance is gimballed it shall be protected by a crash bar or other means to prevent it being tilted inadvertently when it is free to swing and a strap, portable bar or other means shall be provided to allow the cook to be secured in position, with both hands free for working, when the vessel is rolling. Means shall be provided to isolate the gimbaling mechanism.

17.3 There shall be secure stowage for food in the vicinity of the galley.

18 Toilet facilities

18.1 Adequate toilet facilities, separated from the rest of the accommodation, shall be provided for persons on board, the floor of which shall have a non-slip surface.

18.2 In general, there shall be at least one marine type flushing water closet and one wash hand basin for every 12 persons.

19 Stowage facilities for personal effects

Adequate stowage facilities for clothing and personal effects shall be provided for each person on board.

PART D - WORKING DECKS

20 Surface of Working Decks

20.1 The surface of a working deck shall be non-slip. Acceptable surfaces are: chequered plate; unpainted wood; a non-skid pattern moulded into fibre reinforced plastic (FRP); non-slip deck paint; or an efficient non-slip covering.

20.2 A hatch cover fitted on a working deck shall have a non-slip finish.

20.3 In an inflatable boat or rigid inflatable boat the upper surface of the inflated buoyancy tube shall be provided with a non-slip finish.

21 Rails and Guards

21.1 Rails or equivalent protection shall be installed near the periphery of all decks of a vessel accessible to passengers or crew. Equivalent protection may include lifelines, wire rope, chains and bulwarks that provide strength and support equivalent to fixed rails. Deck rails shall include a top rail with the minimum height of 1000mm (39.5 inches) and lower courses or equivalent protection. The distance between the lowest course and the deck shall not exceed 230mm (9 inches) and the distance between the other courses shall not exceed 380mm (15 inches).

21.2 In a vessel fitted with a cockpit, which opens aft to the sea, additional guard rails shall be fitted so that there is no unprotected vertical opening, i.e. between vertical “members,” greater than 500mm in width.

21.3 In an inflatable boat or a rigid inflatable boat, handgrips, toeholds and handrails shall be provided as necessary to ensure the safety of all persons on board during transit and the worst weather conditions likely to be encountered in the intended area of operation.

21.4 Suitable storm rails or hand grabs shall be installed where necessary in passageways, at deckhouse sides and at ladders and hatches.

21.5 On a vessel authorised to carry one or more vehicles, suitable chains, cables or other barriers shall be installed at the end of each vehicle runway and temporary rails or equivalent protection shall be installed in way of each vehicle ramp when the vessel is underway.

CHAPTER III – FREEBOARD, STABILITY AND WATERTIGHT INTEGRITY

PART A - FREEBOARD

1 Minimum Freeboard

1.1 The minimum freeboard shall be that freeboard at which the vessel meets the stability requirements as determined by a simplified stability proof test, carried out in accordance with regulation **III/8** or other requirements that the Administration considers appropriate in relation to the type of vessel, its service and its area of operation. The minimum freeboard shall not be less than 250mm (10 inches). Where the least freeboard of the loaded vessel occurs abaft a point $0.75x$ the length of the vessel from the foreside of the foremost fixed permanent structure, the minimum freeboard shall be taken to be the freeboard measured at that point. The deepest load waterline shall be the loadline equivalent to the minimum freeboard.

1.2 When demonstrating compliance with **III/8.12 or .13**, the freeboard shall be measured as follows:

- .1** For a flush deck or well deck vessel, the freeboard shall be measured to the top of the weatherdeck at the side of the vessel; and
- .2** For a cockpit vessel or for an open boat, the freeboard shall be measured to the top of the gunwale.

2 Loading Marks

A vessel shall have permanent loading marks placed on each side of the vessel forward, amidships and aft to indicate the maximum allowable draft and trim corresponding to the minimum freeboard determined according to regulation **III/1**. Such a loading mark shall be a horizontal line of at least 200mm (8 inches) in length forward and aft and 300mm (12 inches) amidships and 25mm (1 inch) in height, with its upper edge passing through the point of maximum draft. The loading mark shall be painted in a contrasting colour to the sideshell paint.

3 Loading of a vessel

3.1 Except as provided in regulation **III/3.2** the loading marks of a vessel shall not be submerged at any time when a vessel puts to sea, during a voyage or on arrival.

3.2 When a vessel departs from a port situated on a river or inland waters, deeper loading shall be permitted corresponding to the weight of fuel and all other materials required for consumption between the point of departure and the sea.

PART B - STABILITY

4 Stability Information for Operating Personnel

Stability information, i.e. stability details indicated on the Certificate of Inspection, a stability letter or a stability booklet, as determined by the [Administration], is required on all vessels. Sufficient stability information including stability calculations and assumptions made to use them, shall be provided on vessels for the master to be able to determine the stability of the vessel in various loading conditions in relation to accepted standards.

5 Stability Information

5.1 Where the Administration determines in accordance with **III/4**, that a vessel must have a stability booklet, the owner or operator shall prepare the booklet in accordance with Annex 2A and submit it to the Administration for approval.

5.2 Where the Administration determines in accordance with **III/4**, that the stability information shall be in the form of a stability letter or details indicated on the Certificate of Inspection, the owner or operator of the vessel shall submit to the Administration the following information and the necessary calculations used to determine that information:

- .1** allowable number of passengers and crew on each deck;
- .2** Deepest waterline drafts or freeboard;
- .3** location of watertight bulkheads and openings in watertight bulkheads
- .4** explanation of the vessel's subdivision and specific identification of the vessel;s subdivision bulkheads;
- .5** location of openings through watertight bulkheads, such as watertight doors, which must be closed to limit flooding in an emergency;
- .6** location, type and amount of fixed ballast;
- .7** location and details of foam flotation material; and
- .8** maximum weight of portable equipment permitted on the vessel, including diving equipment.

6 Intact stability requirements in general

6.1 A vessel shall undergo a simplified stability proof test in accordance with regulation **III/8** in the presence of an Administration surveyor.

6.2 A simplified stability proof test in accordance with regulation **III/8** is conducted to determine where a vessel, as built and operated, has a minimum level of initial stability. Failure of the simplified test does not necessarily mean that the vessel lacks stability for the intended operating area, service, and operating condition, but that calculations or other methods shall be used to evaluate the stability of the vessel.

6.3 The stability of a vessel certified to operate in exposed waters shall be determined by calculation to the satisfaction of the Administration.

7 Intact stability requirements for a sailing vessel

7.1 Subject to **III/7.3**, each sailing vessel shall undergo a simplified stability proof test in accordance with regulation **III/8**.

7.2 A sailing vessel that operates in coastal or exposed waters shall be equipped with a self-bailing cockpit.

7.3 The Administration may perform operational tests to determine whether the vessel has adequate stability and satisfactory handling characteristics under sail for protected waters or coastal waters, in lieu of conducting a simplified stability proof test.

7.4 The Administration may prescribe additional or different stability requirements for a broad, shallow draft vessel with little or no ballast outside the hull.

8 Simplified stability proof test procedure and assumptions

8.1 A vessel shall be in the condition specified in **III/8.2** to **III/8.8** inclusive when a simplified stability proof test is performed.

8.2 The vessel shall be moored in a quiet, sheltered area free from extraneous forces such as propeller wash from passing vessels, or sudden discharges from shore-side pumps, and in a manner to allow unrestricted heeling.

8.3 The construction of the vessel shall be complete in all respects

8.4 Ballast, where necessary, shall be in compliance with regulation **III/9** and shall be on board and in place.

8.5 Each fuel and water tank shall be approximately three-quarters full.

8.6 A weight equal to the total weight of all passengers, crew, and other loads permitted on the vessel shall be on board and distributed so as to provide normal operating trim and to simulate the vertical centre of gravity causing the least stable condition that is likely to occur in service. For the purposes of regulation **III/8** the crew shall be counted as passengers.

8.7 Unless otherwise specified, weight and vertical centre of gravity is assumed to be as follows:

- .1** the weight of primary lifesaving equipment shall be simulated at its normal location, if not on board at the time of the test;
- .2** the weight of one person is considered to be 75 kg (166 pounds) except where the vessel operates exclusively on protected waters, when passenger loads consist of men, women and children, the weight of one person is considered to be 65 kg (143 pounds);
- .3** the vertical centre for the simulated weight of passengers, crew, and other loads shall be at least 760 mm (2.5 feet) above the relevant deck; and
- .4** where the vessel carries passengers on diving excursions, the total weight of diving gear shall be included in the loaded condition, in the positions they would normally be carried, as follows:
 - .1** the total weight of individual diving gear for each passenger carried is assumed to be 36 kg (80 pounds), which includes the weight of scuba tanks, harness, regulator, weight belt, wet suit, mask, and other personal diving equipment; and
 - .2** the weight of any air compressors carried.

8.8 On vessels having one upper deck above the main deck available to passengers, the vertical weight distribution shall not be less than the following:

$$\text{Weight on Upper Deck} = (\# \text{ of passengers on upper deck}) \times (\text{Wt per passenger}) \times 1.33$$

$$\text{Weight on Main Deck} = \text{Total Test Weight} - \text{Weight on Upper Deck}$$

8.9 All non-return closures on cockpit scuppers or on weather deck drains shall be kept open during the test.

8.10 A vessel shall not exceed the limitations in **III/8.12**, when subjected to the greater of the following heeling moments:

$$M_p = (W)(B_p)/6; \text{ or}$$

$$M_w = (P)(A)(H)$$

where:

M_p = passenger heeling moment in kilogram-metres (foot-pounds);

W = the total passenger weight using 75 kg (165 pounds) per passenger, or, where the vessel operates exclusively on protected waters, 65 kg (143 pounds) per passenger may be used;

B_p = the maximum transverse distance in metres (feet) of a deck that is accessible to passengers;

M_w = wind heeling moment in kilogram-metres (foot-pounds);

P = wind pressure of:

- (a) 36.6 kilograms/square metre (7.5 pounds/square foot) for operation on protected waters;
 - (b) 48.8 kilogram/square metre (10.0 pounds/square foot) for operation on coastal waters;
- or
- (c) 73.3 kilograms/square metre (15.0 pounds/square foot) for operation on exposed waters;

A = area, in square metres (square feet), of the projected lateral surface of the vessel above the waterline, including each projected area of the hull, superstructure and area bounded by railings and structural canopies. For sailing vessels this is the bare poles area, or, where the vessel has no auxiliary power, with storm sails set; and

H = height, in metres (feet), of the centre of area (A) above the waterline, measured up from the waterline.

8.11 For sailing vessels the heeling moment used for this test shall be the greater of the following:

- .1** Passenger heeling moment from **III/8.10**.
- .2** Wind heeling moment from **III/8.10**.
- .3** Wind heeling moment calculated from the wind heeling moment equation in **III/8.10** as $M_w = (P)(A)(H)$,
where:

M_w = wind heeling moment in kilogram-metres (foot-pounds);

$P = 4.9$ kilograms/square metre (1.0 pounds/square foot);

A = the windage area of the vessel in square metres (square feet) with all sails set and trimmed flat;

H = height, in metres (feet), of the centre of effort of area (A) above the waterline, measured up from the waterline.

8.12.1 When a vessel is subjected to the greater of the heeling moments determined in regulation **III/8.10**, the immersion of the loading mark shall not exceed the percentage of the freeboard specified in the following:

- .1** on a flush deck vessel, 50 per cent;
- .2** on a well deck vessel that operates on protected waters and has non-return scuppers or freeing ports, 100 per cent where the full freeboard is not more than one-quarter of the vertical distance from the waterline to the gunwale;
- .3** on all other well deck vessels, 50 per cent
- .4** on a cockpit vessel, the percentage is calculated from the following:
 - on exposed waters: $(2L - 1.5LN)/4L$
 - on protected or coastal waters: $(2L - LN)/4L$
 - where:
 - L = length of the weather deck; and
 - LN = length of cockpit in the same units as L .
- .5** on an open boat, 25 per cent;
- .6** on a flush deck sailing vessel, 100 per cent

8.12.2 Notwithstanding the percentages specified in regulation **8.12.1**, when the vessel is subject to the greater of the heeling moments determined in regulation **III/8.10**, the immersion shall not exceed a value equivalent to one eighth of the beam of the vessel measured at the point of minimum freeboard as defined in regulation **III/1.1**

8.13 Where during a simplified stability proof test a vessel fails to meet the requirements of regulation **III/8.12**, the entire test shall be repeated with a reduced load equivalent to a reduced number of passengers or a reduced weight of cargo or by utilising any other corrective measures available to enable the vessel to meet the requirements of regulation **III/8.12**.

8.14 A ferry shall also be tested by using equivalent weights, by calculation, or other method acceptable to the Administration to determine whether the trim or heel during loading or unloading will submerge the deck edge. A ferry passes this test where, with the total number of passengers and the maximum vehicle weight permitted on board, the deck edge is not submerged during loading or unloading of the vessel.

8.15 The Small Commercial Vessel Stability Test Procedure is given in **Annex 2**.

9 Installation of Ballast

Any solid fixed ballast shall be stowed in a manner that prevents shifting of the ballast and be installed to the satisfaction of the Administration.

10 Open Boats

An open boat when fully loaded shall have sufficient buoyancy to be able to remain afloat and should have a positive metacentric height, that is, the vessel returns to the upright when a heeling moment is applied and removed, when totally flooded. The open boat shall be deemed by the Administration to have sufficient buoyancy by practical test or where detailed calculations are confirmed to show that the buoyancy of the vessel is greater than the total weight of the vessel and its load.

11 Foam flotation material

11.1 Foam may only be installed as flotation material on a vessel when approved by the Administration.

11.2 Where foam is installed as flotation material on a vessel, the owner shall ensure that the following tests are conducted and requirements are met to the satisfaction of the Administration:

- .1 foam shall not be installed in void spaces that contain ignition sources;
- .2 foam shall not be installed adjacent to fuel tanks, unless the boundary between the tank and the space has double continuous fillet welds;
- .3 the structure enclosing foam shall be strong enough to accommodate the buoyancy of the foam;
- .4 piping and cables shall not pass through foamed spaces unless they are within piping and cableways accessible from both ends;
- .5 blocked foam shall:
 - .1 be used in each area that may be exposed to water; and
 - .2 have a protective cover, approved by the administration, to protect it from damage;
- .6 foam used as floatation material shall be:
 - .1 impervious to water absorption;
 - .2 structurally stable under service conditions;
 - .3 chemically inert in relation to other medium with which it may be in contact;
 - .4 properly secured in place; and
 - .5 easily removable for inspection of the void space.
- .7 a water submergence test shall be conducted on the foam for a period of at least 7 days to demonstrate to the satisfaction of the Administration that the foam has adequate strength to withstand a hydrostatic head equivalent to that which would be imposed if the vessel were submerged to its bulkhead deck;
- .8 the owner or operator shall obtain sample foam specimens during installation of the foam and determine the density of the installed foam.

PART C - WATERTIGHT INTEGRITY

12 Drainage of Weather Decks

12.1 The weather deck on all vessels shall be watertight or fitted with closures to ensure watertight integrity. The drainage from the weather deck shall be such that the watertight integrity is not compromised.

12.2 When a deck is fitted with bulwarks such that shipped water may be trapped, the bulwarks shall be provided with efficient freeing ports.

12.3 The area of freeing ports shall be at least 5% of the bulwark area and be situated in the lower third of the bulwark height, the bottom of which shall be flush with the deck.

12.4 A vessel of less than 12 m in length, certified to operate in coastal waters, having a well deck aft and is fitted with bulwarks all round and which always operates with stern trim, may be provided with a minimum of two ports fitted (one port and one starboard) in the transom, each having a clear area of at least 225 sq.cm.

12.5 Where a non-return shutter or flap is fitted to a freeing port it shall have sufficient clearance to prevent jamming and any hinges shall have pins or bearings of non-corrodible material. Normally, hinges shall be along the upper edge of the non-return shutter or flap.

12.6 Where a vessel has side deck areas of less than one-tenth the length of the vessel, in which water can be trapped a smaller freeing port area may be accepted. The reduced area shall be based on the volume of water, which is likely to become trapped.

12.7 In a vessel in which freeing ports cannot be fitted, other efficient means of clearing trapped water from the vessel shall be provided to the satisfaction of the Administration.

12.8 Structures and spaces considered non-weather-tight shall be provided with efficient drainage arrangements.

12.9 Where cargo is to be stowed on deck the stowage arrangement shall be such as to not impede the free flow of water from the deck.

13 Air Pipes

13.1 When located on the weather deck, air pipes shall be kept as far inboard as possible and have a height above deck sufficient to prevent downflooding when heeled in rough water.

13.2 An airpipe of greater than 10mm inside diameter, serving a fuel or other tank shall be provided with a permanently attached means of weather-tight closure.

14 Sea Inlets and Discharges

14.1 An opening below the weather deck shall be provided with an efficient means of closure.

14.2 When the opening is for the purpose of an inlet or discharge below a line drawn 150mm (6 inches) above the loading mark it shall be fitted with a seacock, valve or other positive means of closure, which is readily accessible in an emergency.

14.3 When the opening is for a log or other sensor, which is capable of being withdrawn, it shall be fitted in an efficient watertight manner and provided with an effective means of closure when such a fitting is removed.

14.4 Inlet and discharge pipes from water closets shall be provided with shell fittings as required by **III/14**. When the rim of a toilet is less than 300mm above the deepest waterline of the vessel, anti-siphon measures shall be provided.

15 Materials for Valves and Associated Piping

15.1 A valve or similar fitting attached to the side of the vessel below the waterline, shall be normally of steel, bronze or other non-brittle fire resistant material or equivalent. Valves of ordinary cast iron or similar material are not acceptable.

15.2 When plastic piping is used it shall be of good quality and of a type suitable for the purpose. Any such pipe shall be located so as to minimise the risk of accidental damage. Where fitted within an engine space or fire risk area, a means shall be provided to stop the ingress of water in the event of the pipe being damaged, operable from outside the space.

PART D - SUBDIVISION

16 Collision Bulkheads

16.1 A new vessel of 20 m or more in length is required to have a collision bulkhead fitted in accordance with regulations **III/17.1** and **III/17.2**.

16.2 A new vessel of less than 20 m in length shall have a collision bulkhead where it:

- .1** carries 50 or more passengers; or
- .2** is of more than 12m in length and is certified to operate on coastal waters; or
- .3** is certified to operate on exposed waters;

16.3 A ro ro ferry of 20m or more in length that may operate on its route ahead or astern shall, in addition to the collision bulkhead required by **III/16.1** is required to have a collision bulkhead fitted in accordance with regulations **III/17.1** and **III/17.3**.

16.4 The Administration shall determine the extent to which this regulation is applied to existing vessels.

17 Construction and Location of Collision Bulkheads

17.1 Each collision bulkhead required by regulation **III/16** shall be constructed in accordance with regulation **III/18** except that it shall: -

- .1** extend to the weather deck or to one deck above the bulkhead deck, whichever is lower, in vessels certified to operate on coastal and exposed waters; and
- .2** not be fitted with any type of penetration or opening except penetrations may be made where they are located as high and as far inboard as practicable and they have a means to make them watertight.

17.2 The forward collision bulkhead required to be on a vessel by regulation **III/ 16** shall be:-

- .1** located at least 5 percent but not more than 15 percent of the length between perpendiculars (LBP) aft of the forward perpendicular or for vessels with bulbous

bows extending forward of the forward perpendicular and contributing more than 2 percent of the underwater volume of the vessel the bulkhead shall be located at least 5 percent but not more than 15 percent of the LBP aft of the mid-length of such extension; and

- .2 installed in a single plane, with no recess or step, up to the bulkhead deck.

17.3 The after collision bulkhead on a double-ended ferry of 20 m (65 feet) or more in length required by regulation **III/16.3** shall be:

- .1 located at least 5 percent but not more than 15 percent of the LBP forward of the after perpendicular and; shall be
- .2 installed in a single plane, with no recess or step, at least up to the bulkhead deck.

18 Watertight Subdivision Bulkheads

18.1 Where a vessel is required to be fitted with watertight collision or subdivision bulkheads, each watertight bulkhead shall be of sufficient strength to be capable of remaining watertight with a head of water to the top of the bulkhead.

18.2 Each watertight bulkhead shall extend to the bulkhead deck and shall be installed in one plane without steps or recesses insofar as is reasonable and practicable. Any steps or recesses permitted shall comply with the applicable subdivision requirements in this chapter.

18.3 The number of penetrations in a watertight bulkhead shall be minimised. A penetration in a watertight bulkhead shall be as high and as far inboard in the bulkhead as practicable, and made watertight.

18.4 Sluice valves shall not be permitted in watertight bulkheads.

18.5 A door fitted in a watertight bulkhead shall be of watertight construction and be kept closed at sea, unless opened at the discretion of the Master.

18.6 The Administration shall determine the extent to which this regulation is applied to existing vessels.

19 Subdivision of Cargo Vessels

A new cargo vessel of 12 m or more in length shall be fitted with watertight bulkheads at each end of the main propulsion machinery space.

20 Subdivision of Passenger Vessels

20.1 A new passenger vessel of 20 m or more in length shall be fitted with watertight bulkheads fitted in accordance with regulation **III/21**.

20.2 A new vessel of less than 20 m in length shall have watertight bulkheads in accordance with regulation **III/21**, where it:

- .1 carries 50 or more passengers; or
- .2 is of more than 12m in length and is certified to operate on coastal waters ; or
- .3 is certified to operate in exposed waters .

21 Location of Watertight Bulkheads for Subdivision

21.1 The maximum distance between adjacent main transverse watertight bulkheads on a vessel, required by regulation **III/20** to comply with this regulation, shall not be more than the smaller of the following:

- .1 one third of the length of the bulkhead deck; or
- .2 the distance given by the following equation:

$$d = \frac{(F)(f)(L)}{D}$$

where:

F = the floodable length factor from **Table III/21.1**;

f = the effective freeboard in metres calculated for each pair of adjacent bulkheads in accordance with **III/21.2**;

L = Length Over Deck in metres measured over the bulkhead deck; and

D = the depth in metres (feet), measured amidships at a point one-quarter of the maximum beam out from the centreline, from the inside of the bottom planking or plating to the level of the top of the bulkhead deck. (See **Figure III/21-1**).

TABLE III/21
TABLE OF FLOODABLE LENGTH FACTORS

(d/L)x100	F
0-15	0.33
20	0.34
25	0.36
30	0.38
35	0.43
40	0.48
45	0.54
50	0.61
55	0.63
60	0.58
65	0.53
70	0.48
75	0.44
80	0.40
85	0.37
90-100	0.34

NOTE 1: Where:
d = distance in metres (feet) from the midpoint of the compartment to the forward-most point on the bulkhead deck excluding sheer; and
L = length over deck in metres (feet) measured over the bulkhead deck.

NOTE 2: Intermediate values of floodable length factor may be obtained by interpolation.

Figure III/21-1

Transverse Location for Measuring Depth(D)

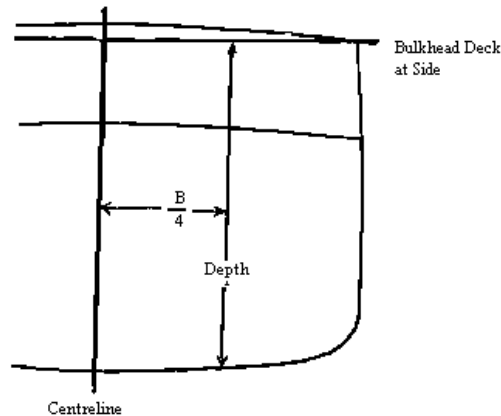

21.2 The effective freeboard for each compartment is calculated by the following equation:

$$f = (a+b)/2$$

where:

f = the effective freeboard in metres (feet).

a = the freeboard in metres (feet) measured:

- .1 at the forward main transverse watertight bulkhead; and
- .2 from the deepest waterline to:
 - .1 the top of the bulkhead deck on a flush deck vessel; and
 - .2 where a vessel has a stepped bulkhead deck, then to the line shown in **Figure III/21-2**; or
 - .3 where a vessel has an opening scuttle (porthole) below the bulkhead deck, then to the line shown in **Figure III/21-3**.

b = the freeboard in metres (feet) measured:

- .1 at the aft main transverse watertight bulkhead; and
- .2 from the deepest waterline to:
 - .1 the top of the bulkhead deck on a flush deck vessel;
 - .2 where a vessel has a stepped bulkhead deck, the line shown in **Figure III/21-2**; or
 - .3 where a vessel has an opening scuttle (porthole) below the bulkhead deck, the line shown in **Figure III-21-3**.

Figure III/21-2

Freeboard Measurement - Vessel with Stepped Bulkhead Deck

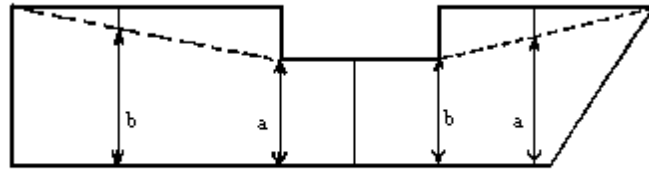

(a and b shown for two sample compartments)

Figure III/21-3

Freeboard Measurement - Vessel with Stepped Bulkhead Deck and a Porthole Below the Bulkhead Deck

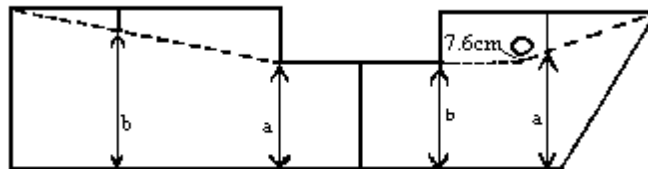

21.3 A vessel, required by regulation III/20 to be fitted with watertight bulkheads shall be measured and subdivided in accordance with the simplified subdivision calculation given in **Annex 3**

CHAPTER IV - MACHINERY

PART A - GENERAL PROVISIONS

1 General requirements

1.1 The design, construction, installation and operation of propulsion and auxiliary machinery, piping and pressure systems, steering apparatus and associated safety systems shall be to the satisfaction of the Administration. These requirements shall be considered to be satisfactory where they are in accordance with the requirements of a classification society recognised by the Administration.

1.2 In all vessels, the main propulsion machinery and all auxiliary machinery essential to the propulsion and the safety of the vessel shall be designed to operate when the vessel is upright and when inclined at any angle of heel and trim up to and including 15° and 7.5° respectively either way under static conditions.

1.3 Starting motors, generators, and any spark producing device shall be mounted as high above the bilges as practicable. Electrical equipment in spaces, compartments, or enclosures that contain machinery powered by, or fuel tanks for, gasoline or other fuels having a flashpoint of 43°C (110°F) or lower shall be explosion-proof, intrinsically safe, or ignition protected for use in a gasoline atmosphere.

1.4 Gauges to indicate engine revolutions per minute (RPM), jacket water discharge temperature, and lubricating oil pressure shall be provided for all propulsion engines installed in the vessel. The gauges shall be readily visible at the operating station.

1.5 A cover, guard or rail shall properly protect an exposed hazard, such as gears or rotating machinery.

1.6.1 Shutoff valves, installed so as to close against the fuel flow, shall be fitted in the fuel supply lines, one at the tank connection and one at the engine end of the fuel line to stop fuel flow when servicing accessories. The shutoff valve at the tank shall be manually operable from outside the compartment in which the valve is located, preferably from an accessible position on the weather deck.

1.6.2 Where the handle to the shutoff valve at the tank is located inside the machinery space, it shall be located so that the operator does not have to reach more than 300 mm (12 inches) into the machinery space and the valve handle shall be shielded from flames by noncombustible material. Electric solenoid valves shall not be used, unless used in addition to the manual valve.

1.7 Fuel filling and venting pipes shall be constructed of fuel compatible non-kinking material, adequately supported and of sufficient dimensions to prevent spillage during filling. A venting pipe shall be led to the open atmosphere, terminating in a position level with or higher than the fuel filling mouth and its open end protected against:-

- .1** water ingress - by a goose neck or other efficient means; and
- .2** flame ingress - by a suitable gauze diaphragm, which can be detached for cleaning.

1.8 An air pipe, of greater than 10mm inside diameter, serving a fuel tank or other tank shall be provided with a closing appliance of a type, which will prevent excessive pressure on the tank boundaries. Provision shall be made for relieving a vacuum when tanks are being drawn from or emptied.

- 1.9** Flexible non-metallic hose may be used in all systems subject to the following:
- .1** when required by the machinery manufacturer, factory-assembled fittings shall be used;
 - .2** hose clamps may be used for other installations of short lengths not to exceed 760 mm (30 inches) and subject to pressures of not more than 35 kPa (5 psi);
 - .3** in a fuel supply system to engine unit the hose shall be fire resistant/metal reinforced or otherwise protected from fire; and
 - .4** they shall be installed and located so as to minimize the risk of accidental damage.
- 1.10** In systems and applications where flexible hoses are permitted by regulation **IV/1.9.2**, to be clamped:
- .1** double hose clamping is required where practicable;
 - .2** the clamps shall be of a corrosion resistant metallic material;
 - .3** the clamps shall not depend on spring tension for their holding power; and
 - .4** two clamps shall be used on each end of the hose, or one hose clamp can be used where the pipe ends are expanded or beaded to provide a positive stop against hose slippage.
- 1.11** An enclosed space containing machinery powered by gasoline or other fuels, having a flash point of 43⁰C (110⁰F) or lower, shall be equipped with a flammable vapour detection device.
- 1.12** Piping used in the following systems shall be of ferrous material or other material where approved by the Administration.
- .1** Fuel system;
 - .2** Fire main;
 - .3** CO₂ system fixed fire fighting;
 - .4** Bilge system;
 - .5** Steering system;
 - .6** Propulsion system and its necessary auxiliaries and controls;
 - .7** Vessel's service and emergency electrical generation system and its necessary auxiliaries; and
 - .8** A system identified by the Administration as being crucial to the survival of the vessel or to the protection of the personnel on board.
- 1.13.1** Diesel tanks may only be integral with the hull where the ship is made of steel, aluminium or GRP, sandwich construction is not acceptable. All other fuel tanks shall be independent of the hull.
- 1.13.2** Independent fuel tanks shall comply with the following:

- .1 the tank shall be constructed of steel or aluminium;
- .2 tubular glass shall be fitted only to a diesel tank and shall be of heat resistant material, protected from mechanical damage, and provided with tank connection devices that automatically close if the glass is ruptured;
- .3 where any dimension of the tank exceeds 760mm (30) inches, the tank shall be fitted with baffle plates to maintain strength and control the excessive surge of fuel;
- .4 the interior of the tank shall be covered with a protective coating suitable for the type of fuel carried.

1.13.3 Fuels tanks shall be pressure tested to 35kPa (5psi).

1.13.4 Fuel tanks shall be electrically bonded to a common ground.

1.13.5 Fuel tanks shall be adequately supported and braced to prevent movement.

2. Gasoline engines for propulsion

2.1 A vessel may be fitted with an inboard gasoline engine where:-

- .1 the engine is located in an efficiently enclosed space to which a fixed fire extinguishing system is fitted;
- .2 provision is made to ventilate the engine space thoroughly before the engine is started;
- .3 electrical devices within the engine and tank compartments have protection against ignition of surrounding flammable gasses;
- .4 any flexible hose used between the engine and any solidly mounted metallic line to eliminate vibration failure is made of fire resistant fuel hose;
- .5 not more than 12 passengers are carried; and
- .6 the vessel is certified to operate only in coastal waters.

2.1 A vessel fitted with one or more outboard gasoline engines:-

- .1 shall be certified to operate in coastal waters only;
- .2 shall have the engines securely fastened to the hull;
- .3 where the engines are not permanently secured, the engines shall be provided with an effective safety chain or cable;
- .4 shall have effectively drained engine wells that are long enough for the engine to be tilted up; and
- .5 where the vessel is fitted with a single outboard engine, it shall, where it proceeds beyond protected waters, have an auxiliary outboard engine of sufficient power to enable the vessel to return safely to port or a safe haven.

2.3 Gasoline for outboard motors shall be stored:-

- .1** in portable containers that can be readily jettisoned; or
- .2** in a fixed-in-place inboard tank independent of the hull, where:-
 - .1** the vessel is a rigid hulled vessel or rigid/inflatable boat;
 - .2** the tank is constructed of mild steel or stainless steel and located in a safe place;
 - .3** the tank is tested to a pressure of 0.3 bar, to the satisfaction of a surveyor;
 - .4** the opening of the vent pipe from the petrol tank is protected by a flash proof fitting; and
 - .5** where the possibility of accumulation of hydrocarbon vapours exists and where a source of ignition may be present, a safe detector of hydrocarbon gas is fitted under or adjacent to the tank.
- .3** electrical devices within the engine and fuel tank compartments shall be protected against ignition of any surrounding flammable gasses (explosion proof).

3 Ventilation of Spaces relating to Gasoline

3.1 A space containing machinery powered by, or fuel tanks for, gasoline shall have a ventilation system that complies with this regulation and consist of the following:

- .1** for an enclosed space:
 - .1** at least two natural ventilation supply ducts located at one end of the space and that extend to the lowest part of the space or to the bilge on each side of the space; and
 - .2** a mechanical exhaust system consisting of at least two ventilation exhaust ducts located at the end of the space opposite from where the supply ducts are fitted, which extend to the lowest part or the bilge of the space on each side of the space, and which are led to one or more powered exhaust blowers; and
- .2** For a partially enclosed space, at least one ventilation duct installed in the forward part of the space and one ventilation duct installed in the after part of the space, or as otherwise required by the Administration. Ducts for partially enclosed spaces shall have cowls or scoops as required by **IV/3.9**.

3.2 A mechanical exhaust system required by regulation **IV/3.1.1(b)** shall be such as to assure the air changes as noted in **Table IV.3.2** depending upon the size of the space.

TABLE IV.3.2

Size of space in cubic metres (cubic feet)		Minutes per air change
Over	Not over	
0	14 (500)	2
14 (500)	28.50 (1000)	3
28.50 (1000)	43 (1500)	4
43 (1500)	5

3.3 An exhaust blower motor where mounted in any space required to be ventilated by this regulation, shall be located as high above the bilge as practicable. Blower blades shall be non-sparking with reference to their housings.

3.4 Where a fixed gas fire extinguishing system is installed in a space, all powered exhaust blowers for the space shall automatically shut down upon release of the extinguishing agent.

3.5 Exhaust blower switches shall be located outside of any space required to be ventilated by this regulation, and shall be of the type interlocked with the starting switch and the ignition switch so that the blowers are started before the engine starter motor circuit or the engine ignition is energised. A red warning sign at the switch shall state that the blowers shall be operated prior to starting the engines for the time sufficient to insure at least one complete change of air in the space served.

3.6 The area of the ventilation ducts shall be sufficient to limit the air velocity to a maximum of 10 m/s(2,000 ft/min). A duct may be of any shape, provided that in no case will one cross sectional dimension exceed twice the other.

3.7 A duct shall be so installed that ordinary collection of water in the bilge will not block air flow.

3.8 A duct shall be of rigid permanent construction, which does not allow any appreciable vapour flow except through normal openings, and made of the same material as the hull or of non-combustible material. The duct shall lead as directly as possible from its intake opening to its terminus and be securely fastened and supported.

3.9 A supply duct shall be provided at its intake opening with a cowl or scoop having a free area not less than twice the required duct area. When the cowl or scoop is screened, the mouth area shall be increased to compensate for the area of the screen wire. A cowl or scoop shall be kept open at all times, except when the weather is such as to endanger the vessel if the openings are not temporarily closed.

3.10 A duct opening may not be located where the natural flow of air is unduly obstructed, adjacent to possible sources of vapour ignition, or where exhaust air may be taken into a supply duct.

3.11 Provision shall be made for closing all supply duct cowls or scoops and exhaust duct discharge openings for a space protected by a fixed gas extinguishing system. All closure devices shall be readily available and mounted in the vicinity of the vent.

4. Ventilation of spaces relating to diesel.

4.1 A space containing diesel machinery shall be fitted with at least two ducts to furnish natural or powered supply and exhaust ventilation. The total inlet area and the total outlet area of each ventilation duct shall not be less than 650 mm² (one square inch) for each 300 cm (foot) of beam of the vessel. These minimum areas shall be increased as necessary when the ducts are considered as

part of the air supply to the engines.

4.2 A duct shall be of rigid permanent construction, which does not allow any appreciable vapor flow except through normal openings, and made of noncombustible material. The duct shall lead as directly as possible from its intake opening to its terminus and be securely fastened and supported.

4.3 A supply duct shall be provided with a cowl or scoop having a free area not less than twice the required duct area, which shall be kept open at all times except when the weather is such as to endanger the vessel if the openings are not temporarily closed.

4.4 Dampers shall not be fitted in a supply duct.

4.5 A duct opening shall not be located where the natural flow of air is unduly obstructed, adjacent to possible sources of vapor ignition, or where exhaust air may be taken into a supply duct.

4.6 Provision shall be made for closing all supply duct cowls or scoops and exhaust duct discharge openings for a space protected by a fixed gas extinguishing system. All closure devices shall be readily available and mounted in the vicinity of the vent.

4.7 A space containing a diesel fuel tank and no machinery shall meet the following requirements: -

- .1** A space of 14 m³ (500 ft³) or more in volume shall have a gooseneck vent of not less than 65 mm (2.5 inches) in diameter.
- .2** A space of less than 14 m³ (500 ft³) in volume shall have a gooseneck vent of not less than 40 mm (1.5 inches) in diameter.
- .3** Vent openings shall not be located adjacent to possible sources of vapor ignition.

5 Exhausts

An engine exhaust outlet, which penetrates the hull below the weather deck, shall be provided with means to prevent backflooding into the hull through the exhaust system. The means may be provided by system design or arrangement, built-in valve or a portable fitting, which can be applied readily in an emergency.

6 Engine Starting

6.1 An engine shall be provided with either:

- .1** hand starting;
- .2** mechanical;
- .3** electric starting with independent batteries installed in accordance with regulation **IV/21**; or
- .4** other means of starting acceptable to the Administration.

6.2 When the sole means of starting is by battery, the battery shall be installed in accordance with regulation **IV/21** and be in duplicate and connected to the starter motor by means of a "change over switch" so that either battery or both can be used for starting the engine. In normal circumstances, the use of both batteries in parallel should be avoided to prevent simultaneous discharge of both batteries.

Charging facilities shall be available for the batteries when the engine is running.

7 Portable Plant

7.1 Any portable plant provided on board powered by a petrol engine shall be fitted on the weather deck and properly secured to prevent movement.

7.2 A deck locker or protective enclosure for the portable plant shall have no openings to an enclosed space within the hull of the vessel and the locker or protective enclosure shall be adequately ventilated and drained.

7.3 Petrol tanks provided for the engine shall comply with the following:

- .1** fuel is supplied to the engine from a portable tank of 27 litres or less in capacity complying with the requirements of ISO 13591 - Portable fuel systems for outboard motors – or its equivalent National Standard; and
- .2** a small marinised petrol engine, of less than 3.75 kW (5 horse power), manufactured with an integral fuel tank is acceptable for either outboard propulsion or portable plant provided a safety warning sign is displayed with details of appropriate precautions to be taken when filling the fuel tank.

8 Propulsion Engine Control Systems

8.1 A vessel shall have a reliable means for shutting down a propulsion engine, at the main operating station, which is independent of the engine's speed control.

8.2 A propulsion engine control system, including control at the operating station, shall be designed so that a loss of power to the control system does not result in an increase in shaft speed or propeller pitch.

PART B - STEERING AND PROPELLER SYSTEMS

9 Main Steering Gear

9.1 A vessel shall be provided with main steering gear that is:

- .1** of adequate strength and capable of steering the vessel at all service speeds;
- .2** designed to operate at maximum astern speed without being damaged or jammed; and
- .3** capable of moving the rudder from 35° on one side to 30° on the other side in not more than 28 seconds with the vessel moving ahead at maximum service speed.

9.2 Control of the main steering gear, including control of any necessary associated devices, motor, pump, valve, etc., shall be provided from the operating station.

9.3 The main steering gear shall be designed so that transfer of control from the main steering gear to the auxiliary means of steering required by regulation **IV/10** can be achieved rapidly. Any tools or equipment necessary to make the transfer shall be readily available.

9.4 The vessel's operating station shall be arranged to permit the person steering to have the best possible all around vision.

9.5 Strong and effective rudder stops shall be provided to prevent jamming and damage to the rudder and its fittings. These stops may be structural or internal to the main steering gear.

9.6 In addition to meeting the requirements of **IV/9.1** to **9.5**, a vessel with a power driven main steering gear shall be provided with the following:

- .1** a disconnect switch located in the steering compartment, and instantaneous short circuit protection for electrical power and control circuits sized and located to the satisfaction of the Administration;
- .2** an independent rudder angle indicator at the operating station;
- .3** an arrangement that automatically resumes operation, without reset, when power is restored after a power failure;
- .4** a manual means to centre and steady the rudder(s) in an emergency; and
- .5** a limit switch to stop the steering gear before it reaches the rudder stops required by **IV/9.5**.

9.7 A vessel of more than 20 m (65 feet) in length with a power driven main steering gear shall in addition be provided with the following:

- .1** a visual means, located at the operating station, to indicate operation of the power units; and
- .2** instructions for transfer procedures from the main steering gear or control to the auxiliary means of steering required by regulation **IV/8**, posted at the location where the transfer is carried out.

10 Auxiliary Means of Steering

10.1 Except as provided in **IV/10.3**, a vessel shall be provided with an auxiliary means of steering that is:

- .1** of adequate strength;
- .2** capable of moving the rudder from 15^0 on one side to 15^0 on the other side in not more than 60 seconds with the vessel at one-half its maximum service speed ahead, or 7 knots, whichever is greater; and
- .3** controlled from a location that permits safe manoeuvring of the vessel and does not expose the person operating the auxiliary means of steering to personnel hazards during normal or heavy weather operation.

10.2 A suitable hand tiller may be used as the auxiliary means of steering.

10.3 An auxiliary means of steering need not be provided where:

- .1** the main steering gear and its controls are provided in duplicate;
- .2** multiple propeller propulsion, with independent control from the operating position for each screw, is provided, and the vessel is capable of being steered from the control station;
- .3** no regular rudder is fitted and steering action is obtained by a change of setting of the propelling unit; or

.4 where a rudder and hand tiller are the main steering gear.

11 Propeller Systems

Construction and fitting standards for propellers and associated fittings shall be to the satisfaction of the Administration. Recognised design standards shall be used.

PART C - BILGE SYSTEMS

12 General Provisions for Bilge Systems

A vessel shall be provided with a satisfactory arrangement for draining any watertight compartment, other than small buoyancy compartments, under all practicable conditions. Sluice valves shall not be fitted in watertight bulkheads.

13 Bilge piping system

11.1 A vessel of 8 m (26 feet) or more in length shall be provided with individual bilge lines and bilge suction for each watertight compartment, except that the space forward of the collision bulkhead need not be fitted with a bilge suction line when the arrangement of the vessel is such that ordinary leakage may be removed from this compartment by the use of a hand portable bilge pump or other equipment, and such equipment is provided.

13.2 A bilge pipe in a vessel of less than 20 m (65 feet) in length shall be not less than 25 mm (1 inch) nominal pipe size. A bilge pipe in a vessel of 20 m or more (65 feet) in length shall be not less than 40 mm (1.5 inches) nominal pipe size. A bilge suction shall be fitted with a suitable strainer having an open area not less than three times the area of the bilge pipe.

13.3 Except when individual pumps are provided for separate spaces, individual bilge suction lines shall be led to a central control point or manifold and provided with a stop valve at the control point or manifold and a non-return valve at some accessible point in the bilge line. A stop non-return valve located at a control point or manifold will meet the requirements for both a stop valve and a non-return valve.

13.4 A bilge pipe piercing the collision bulkhead shall be fitted with a screw-down valve located on the forward side of the collision bulkhead and operate from the weather deck, or, where it is readily accessible under service conditions, a screw-down valve without remote operation may be fitted to the bilge line on the after side of the collision bulkhead.

14 Bilge pumps

14.1 A vessel shall be provided with bilge pumps in accordance with **Table IV.14.1**. A second power pump is an acceptable alternative to a hand pump where it is supplied by a source of power independent of the fixed power bilge pump. Individual power pumps used for separate spaces are to be controlled from a central control point and shall have a light or other visual means at the control point to indicate operation.

TABLE IV/14.1

Number of passengers	Length of vessel	Bilge Pumps required	Min. capacity required per pump	
			ltrs/min	(gal/min)
Any number	20 m (65 ft) or more	2 fixed power pumps	190	(50)
50 or more passengers	Less than 20 m (65 ft)	1 fixed power pump; and 1 portable hand pump;	95 38	(25) (10)
Less than 50 passengers	8 m (26 feet) and over and less than 20 m (65 ft)	1 fixed power pump and 1 portable hand pump; or	38 19	(10) (5)
		1 fixed hand pump and. 1 portable hand pump;	38 19	(10) (5)
	Less than 8 m (26 feet)	1 portable hand pump.	19	(5)

14.2 A portable hand bilge pump shall be:

- .1 capable of pumping water, but not necessarily simultaneously, from all watertight compartments; and
- .2 provided with suitable suction and discharge hoses capable of reaching the bilges for each watertight compartment.

14.3 Each fixed power bilge pump shall be self-priming. It may be driven off the main engine or other source of power. It shall be permanently connected to the bilge manifold and may also be connected to the fire main. A power bilge pump may also serve as a fire pump provided it meets the requirements of regulation V/7.

14.4 Where two fixed power bilge pumps are installed, they shall be driven by different sources of power. Where one pump is driven off the main engine in a single propulsion engine installation, the other shall be independently driven. In a twin propulsion engine installation, each pump may be driven off a different propulsion engine.

14.5 A submersible electric bilge pump may be used as a power bilge pump required by **Table IV.14.1** only on a vessel of less than 20 m (65 feet) in length carrying less than 50 passengers, other than a ferry, provided that:

- .1 the pump is listed by Underwriters' Laboratories Inc. or another independent laboratory;
- .2 the pump is used to pump out not more than one watertight compartment;
- .3 the pump is permanently mounted;
- .4 the pump is equipped with a strainer that can be readily inspected and cleaned without removal of the pump;
- .5 the pump discharge line is suitably supported;

- .6 the opening in the hull for the pump discharge shall be placed so that it is above the waterline when the vessel is heeled and trimmed to 15 degrees and 7½ degrees respectively;
- .7 a positive shutoff valve is installed at the hull penetration; and
- .8 the capacity of the electrical system, including wiring, and size and number of batteries, is designed to allow all bilge pumps to be operated simultaneously.

14.6 A flexible tube or hose may be used instead of fixed pipe for the discharge line of a submersible electric bilge pump provided the hose or tube does not penetrate any required watertight bulkheads. It shall be of good quality and of substantial construction, suitable for the intended use; and highly resistant to salt water, petroleum oil, heat, and vibration, and shall be located so as to minimize the risk of accidental damage..

14.7 Where a fixed hand pump is used to comply with **Table IV.14.1**, it shall be permanently connected to the bilge system.

14.8 On a vessel of less than 20 m (65 feet) in length, a power driven fire pump required by regulation **V/7** may serve as a fixed power bilge pump required by regulation **IV/14.1**, provided it has the minimum flow rate required by **Table IV.14.1**.

14.9 On a vessel of 20 m or more (65 feet) in length, a power driven fire pump required by regulation **V/7** may serve as one of the two fixed power bilge pumps required by regulation **IV/14.1**, provided it has the minimum flow rate required by **Table IV.14.1**.

14.10 Where the bilge and fire pump systems are interconnected, the dedicated bilge pump is to be capable of pumping the bilges overboard at the same time as the fire/bilge pump charges the firemain. Stop valves and check valves shall be installed in the piping to isolate the systems during simultaneous operation and prevent possible flooding through the bilge system.

14.11 A catamaran vessel shall be equipped with bilge pumps for each hull, as if each hull is a separate vessel, in accordance with **Table IV.14.1**, except where:

- .1 one dedicated pump is located in each hull;
- .2 each dedicated pump is driven by an independent source of power; and
- .3 the bilge pumping system is permanently cross-connected between hulls to facilitate pumping of either hull by either bilge pump.
- .4 isolating valves shall be fitted within the cross connection to prevent flooding from one hull to another.

15 Bilge high level alarms

15.1 On a vessel 8 m (26 feet) or more in length, a visual and audible alarm shall be provided at the operating station to indicate a high water level in each of the following normally unmanned spaces:

- .1 a space with a through-hull fitting below the deepest load waterline, such as a lazarette;

- .2 a machinery space bilge, bilge well, shaft alley bilge, or other spaces subject to flooding from sea water piping within the space; and
- .3 a space with a non-watertight closure, such as a space with a non-watertight hatch on the main deck.

15.2 Vessels constructed of wood shall, in addition to **IV/15.1**, provide bilge level alarms in all watertight compartments except buoyancy chambers of less than 0.25 m³.

15.3 A visual indicator shall be provided at the operating station to indicate when any automatic bilge pump is operating

PART D - ELECTRICAL ARRANGEMENTS

16 General Provisions

16.1 The requirements for the design, construction, installation and operation of electrical equipment and systems including power sources, lighting, motors, miscellaneous equipment and safety systems shall be in accordance with accepted standards or to the satisfaction of the Administration.

16.2 Electrical equipment on a vessel shall be installed and maintained to:

- .1 provide services necessary for safety under normal and emergency conditions;
- .2 protect passengers, crew, other persons, and the vessel from electrical hazards, including fire, caused by or originating in electrical equipment, and electrical shock;
- .3 minimize accidental personnel contact with energized parts; and
- .4 prevent electrical ignition of flammable vapors.

16.3 Electrical equipment used in the following locations shall be drip-proof:

- .1 a machinery space;
- .2 a location normally exposed to splashing, water washdown, or other wet conditions within a galley, a laundry, or a public washroom or toilet room that has a bath or shower; or
- .3 another space with a similar moisture level.

16.4 Electrical equipment exposed to the weather shall be watertight.

16.5 Electrical equipment exposed to corrosive environments shall be demonstrated to be of suitable construction and corrosion- resistant.

16.6 Electrical equipment and installation shall be designed and installed so that it is not affected by vessel motions or vibration of the vessel underway.

16.7 All equipment, including switches, fuses, lampholders, etc., shall be rated for the voltage and current utilized.

16.8 Receptacle outlets of the type providing a grounded pole or a specific direct current polarity shall be of a configuration that will not permit improper connection.

16.9 All electrical equipment and circuits shall be clearly marked and identified.

16.10 Any cabinet, panel, box or other enclosure containing more than one source of power shall be fitted with a sign warning persons of this condition and identifying the individual circuits.

17 Power Sources

17.1 Each vessel that relies on electricity to power the following loads shall be arranged so that the loads can be energized from two sources of electricity:

- .1** fuel system;
- .2** fire main;
- .3** fixed fire fighting systems;
- .4** bilge system;
- .5** steering system;
- .6** propulsion system and its necessary auxiliaries and controls;
- .7** vessel's service and emergency electrical generation system and its necessary auxiliaries;
- .8** a system identified by the Administration as being crucial to the survival of the vessel or to the protection of the personnel on board;
- .9** interior lighting except for decorative lights;
- 10** communication systems including a public address system required under regulation **VII/6**;
- .11** navigation equipment and lights; and
- .12** illumination of the survival craft launching and embarkation areas and man overboard rescue equipment and rescue areas.

17.2 A vessel with batteries of adequate capacity to supply the loads specified in **IV/17.1** for three hours, or a generator or alternator driven by a propulsion engine, complies with the requirement of **IV/17.1**.

17.3 Where a vessel service generator driven by a propulsion engine is used as a source of electrical power, a vessel speed change, throttle movement or change in direction of the propeller shaft rotation shall not interrupt power to any of the loads specified in **IV/17.1**.

17.4 Each generator and motor shall be:

- .1** in a location that is accessible, adequately ventilated, and as dry as practicable; and
- .2** mounted above the bilges to avoid damage by splash and to avoid contact with low lying vapors.

17.5 A voltmeter and an ammeter shall be provided for a generator rated at 50 volts or more. For each alternating current generator, a means for measuring frequency shall also be provided.

17.6 Each generator shall be protected by an overcurrent device with set value not exceeding 115 per cent of the generator full load rating.

17.7 A dual voltage generator installed on a vessel shall be of the grounded type, where:

- .1** the neutral of a dual voltage system shall be solidly connected at the switchboard's neutral bus; and
- .2** the neutral bus shall be connected to ground.

18 Electrical Systems

18.1 Electrical systems shall be two wire.

18.2 A system in which there is no intentional connection of the circuit to earth (an insulated system) shall be provided with double pole switches, except that single pole switches may be used in the final sub-circuit.

18.3 Single pole switches are accepted in a system with one pole earthed. Fuses shall not be installed in an earthed conductor.

18.4 The insulation resistance, using a low voltage instrument so as not to cause damage, shall not be less than 0.3 megohm for all new vessels, but a minimum of 0.1 megohm can be accepted on existing vessels.

18.5 All circuits, except the main supply from the battery to the starter motor and electrically driven steering motors, shall be provided with electrical protection against overload and short circuit, i.e. fuses or circuit breakers shall be installed. Short circuit protection shall be for more than twice the total rated current of the loads in the circuit protected.

18.6 Steering motors shall have an overload alarm in lieu of overload protection.

19 Cables and Wiring

19.1 Electrical cables shall be constructed and fitted to a recognised standard for marine use.

19.2 Cables which are not provided with electrical protection shall be kept as short as possible and shall be "*short circuit proofed*" e.g. single core with additional insulated sleeve over the insulation of each core. Single core marine cable, which has conductor insulation and a sheath will meet this requirement without an additional sleeve.

19.3 All wiring shall be carried out with flame retardant cable. When selecting cables for relevant applications, particular attention shall be given to environmental factors such as temperature and contact with damaging substances e.g. oils and chemicals.

19.4 Adequate provision shall be made for securing electrical connections, e.g. by use of locking washers.

19.5 Electrical cables shall be installed with due regard to minimizing physical damage and the effect of moisture.

20 Batteries

20.1 Where provisions are made for charging batteries, there shall be natural or induced ventilation sufficient to dissipate the gases generated.

20.2 Each battery shall be located as high above the bilge as practicable, secured to protect against shifting with the roll and pitch of the vessel, and free from exposure to water splash or spray.

20.3 Connections shall be made to battery terminals with permanent type connectors. Spring clips or other temporary clamps are prohibited.

20.4 A battery cut-out switch which acts as an isolator shall be provided for all systems. Where a battery change-over switch is fitted and is provided with an "off" position, this may serve as the cut-out switch also.

20.5 Batteries shall be mounted in trays lined with, or constructed of, a material that is resistant to damage by the electrolyte.

20.6 Battery chargers shall have an ammeter connected in the charging circuit.

20.7 Batteries used for engine starting shall be located as close as possible to the engine or engines served.

21 Battery Installation

21.1 Each battery installation connected to a battery charger having an output of more than 2 kW, shall be located in a locker, room or enclosed box solely dedicated to the storage of batteries with adequate ventilation.

21.2 Each battery installation connected to a battery charger having an output of 2 kW or less, shall be located in a well ventilated space and protected from falling objects and shall not be in a closet, storeroom or similar space.

22 General grounding requirements

22.1 A vessel's hull shall not carry current as a conductor except for the following systems:

- .1** impressed current cathodic protection systems; or
- .2** battery systems for engine starting.

22.2 Receptacle outlets and attachment plugs for portable lamps, tools, and similar apparatus operating at 100 volts or more, shall have a grounding pole and a grounding conductor in the portable cord.

22.3 Each nonmetallic mast and top mast shall have a lighting ground conductor.

23 Lighting

23.1 A single hazardous event shall not be capable of disabling all lighting systems.

23.2 Lighting circuits shall be distributed through the spaces so that a total blackout cannot occur due to the failure of a single protective device.

23.3 Where general lighting is provided by a single centralised source, an alternative source of lighting shall also be provided sufficient to enable persons to make their way to the open deck or to permit work on essential machinery.

24 Hazardous Spaces

24.1 Where practicable, electrical equipment shall not be installed in a space where petroleum vapour or other hydrocarbon gas may accumulate. When equipment is installed in such a space it shall comply with a recognised standard for prevention of ignition of flammable atmosphere.

24.2 Any compartment which contains a gas consuming appliance or any compartment into which flammable gas may leak or accumulate, shall be provided with a hydrocarbon gas detector and alarm. The detector and alarm shall be designed to comply with a recognised standard for prevention of ignition of flammable atmosphere.

CHAPTER V - FIRE PROTECTION

PART A - GENERAL PROVISIONS

1 Fire Protection Provisions

1.1 Machinery and fuel tank spaces shall be separated from accommodation spaces by boundaries, which prevent the passage of vapours.

1.2 Paint and flammable liquid lockers shall be constructed of steel or equivalent material.

1.3 Vapour barriers shall be provided in spaces where flammable and combustible liquids or vapours are present.

1.4 Survival craft shall be protected from fire hazards. Where a survival craft is stowed directly above an area of fire hazard, the structure separating the survival craft and the area of fire hazard shall be constructed to comply with A-15 structural fire protection standard.

2 Machinery Space - Construction

2.1 Steel Construction: Vessels which have the machinery space boundaries constructed of steel, require no additional fire protection. However, the surfaces of machinery space bulkheads that are outside of the machinery space shall be coated only with finishes which meet the requirements for low flame spread when tested in accordance with Resolution A.653 (16) of the International Maritime Organization*.

2.2 Fibre Reinforced Plastic (FRP) Construction: Machinery space boundaries should prevent the passage of smoke and flame for 15 minutes, when tested in accordance with the procedure shown in **Annex 4**. Fire resistance of FRP may be achieved by the use of woven roving glass layers or additives to the resin, or by insulation. Intumescent polyester resin surface coatings may also be used; however, solvent-borne intumescent paints shall not be used. The Administration may waive the requirement for the test described in **Annex 4** where the construction complies with an ISO or equivalent standard to give at least the same level of protection.

2.3 Aluminium and Wood Construction: Machinery space boundaries shall have an equivalent level of fire protection when compared with GRP construction as required in regulation **V/2.2**.

2.4 Machinery space boundaries shall be as gastight as practicable so that in the event of a fire the fire extinguishing medium released or injected can be retained for sufficient time to extinguish the fire.

2.5 Where it is not practical to have a machinery space, the engine shall be enclosed in a box. The box shall perform the same function as the machinery space boundaries in regulation **V/2.4**.

2.6 Portlights or windows shall not be fitted in the boundary of the machinery space, except that an observation port having a maximum diameter of 150mm may be fitted, provided the frame is constructed of steel or brass and the port is fitted with a permanently attached steel or brass cover with securing arrangements.

* IMO Resolution A.653(16) - Recommendation on improved fire test procedures for surface flammability of bulkhead, ceiling and deck finish materials.

3 Insulation

3.1 Insulating materials fitted in the machinery space of new vessels shall be non-combustible when tested in accordance with Resolution A.799(19)* of the International Maritime Organization. Insulating materials fitted in the engine space of existing vessels shall not be readily ignitable. Insulation shall be covered with a material impervious to oil or oil vapour.

3.2 Any insulation composite may be considered not readily ignitable where the test defined in **Annex 5** is carried out on a representative specimen and the result is satisfactory. In such testing, the specimen edge need not be tested where the insulation is fitted without exposed edges and specimen conditioning may be curtailed as appropriate to the material under test.

3.3 On existing vessels where insulation is readily ignitable, it shall be replaced as soon as possible, but not later than three years of the coming into force of the Code.

4 Cooking Appliances

4.1 Fire protection arrangements in cooking spaces shall be in accordance with the following:

- .1** in the case of a small cooking area that is common with the accommodation, the structural fire protection fitted shall be dependent on the fire hazard presented by the cooking appliances in the area;
- .2** cooking appliances such as deep-fat fryers or other appliances presenting a high fire hazard are not permitted unless the compartment in which they are situated is fitted with a fixed fire extinguishing system;
- .3** suitable fire retardant barriers shall be built around the cooking and heating appliances where they are adjacent to combustible materials and structures;
- .4** cooking range exhaust hoods and ducts shall be fitted with a grease trap;
- .5** combustible materials not needed in the cooking area shall be stored away from the area;

Materials which are in the vicinity of an open flame cooking appliance shall be non-combustible, except that these materials may be faced with any surface finish which meet the requirements for low flame spread when tested in accordance with Resolution† A.653(16) of the International Maritime Organization.

4.2 Combustible materials and other surfaces which do not meet the requirements for low flame spread shall not be left unprotected within the following distances of the cooker:-

- .1** 600mm vertically above the cooker, for horizontal surfaces,
- .2** 600mm horizontally from the cooker, for vertical surfaces.

4.3 Curtains shall not be fitted within 900mm of an open flame cooking appliance.

* IMO Resolution A.799(19) – Revised recommendation on test methods for qualifying marine construction materials as non-combustible.

† IMO Resolution A.653(16) – Recommendation on improved fire test procedures for surface flammability of bulkhead, ceiling and deck finish materials.

5 Fire Safety

5.1 When spare petrol is carried on board in portable containers for any purpose, the containers shall be clearly marked and shall be stowed on the weather deck where they can be readily jettisoned and where spillage will drain directly overboard. Except as approved by the Administration a portable container shall not exceed 27 litres (6 gallons) and the quantity of petrol and number of containers shall be kept to a minimum.

5.2 Combustible materials not required for the operation and maintenance of machinery, shall not be stowed in the machinery space. Any materials stowed in the machinery space shall be properly secured and cause no obstruction to access in or from the space.

5.3 Gas welding and cutting equipment, where carried, shall be stowed in secure manner on the open deck at a safe distance away from any potential source of fire and shall have the capability of being readily jettisoned overboard where necessary.

5.4 Machinery containing oil shall be provided with a readily accessible galvanised steel drip tray or other suitable means to collect and retain leakages containing oil. The machinery space shall be kept clean and tidy. Oily water shall be collected and properly disposed of ashore.

5.5 Fire hazards shall be minimised in so far as it is reasonable and practicable and combustible materials shall be insulated from heated surfaces such as exhaust pipes and manifolds.

5.6 Savealls or equivalent means of containment of spillage shall be provided below fuel pumps and filters.

PART B - FIRE EXTINGUISHING AND DETECTING EQUIPMENT

6 Equipment installed but not required

Fire extinguishing and detecting equipment installed on a vessel in excess of the requirements shall be designed, constructed, installed and maintained in accordance with a recognised industry standard acceptable to the Administration.

7 Fire pumps

7.1 A self priming, power driven fire pump or a hand pump shall be installed on each vessel of 15 m (50feet) or more in length. The power driven pump shall be capable of projecting a jet of water at least 7.5 m (25 feet) from the nozzle of a hose attached to any hydrant in the system with one hydrant open. The hand pump shall be capable of delivering one jet of water to any part of the ship through a hose and nozzle.

7.2 A fire pump may be driven by a propulsion engine where the propeller shaft can be readily disengaged or a controllable pitch propeller is fitted. A fire pump shall be permanently connected to the fire main where fitted and may be connected to the bilge system.

7.3 Where the fire pump is located in the machinery space, it shall be capable of both remote operation from the operating station and local, manual operation at the pump.

8 Fire main and hydrants

A vessel that has a power driven fire pump shall have a sufficient number of fire hydrants to reach any part of the vessel using a single length of fire hose.

9 Fire hoses and nozzles

9.1 A fire hose with a nozzle shall be attached to each fire hydrant at all times. For fire stations located on open decks or cargo decks, where no protection is provided, hoses may be temporarily removed during heavy weather or cargo handling operations, respectively. Hoses so removed shall be stored in nearby accessible locations.

9.2 On a vessel of less than 20 m (65 feet) in length, carrying 50 or more passengers, and on a vessel of 20 m (65 feet) in length or over, each hose shall be to recognized standards and be not less than 7.5 m (25 feet) or more than 15 m (50 feet) in length and 40 mm (1.5 inches) in diameter. It shall have fittings of brass or other suitable material.

9.3 Each fire hose on a vessel of less than 20 m in length carrying less than 50 passengers shall be approved by the Administration and be of one piece not less than 7.5 m (25 feet) and not more than 15 m (50 feet) in length. It shall have fittings of brass or other suitable material.

9.4 Each nozzle shall be of corrosion-resistant material and be capable of being changed between a solid stream and a spray pattern. A nozzle on a vessel of less than 20 m (65 feet) in length carrying 50 or more passengers, and on a vessel of 20 m or more in length, shall be of a type approved by the Administration.

10 Requirement for Fixed Fire Extinguishing and Detecting Systems

10.1 Subject to **V/10.2**, the following spaces shall be equipped with a fixed gas or other fixed fire extinguishing system approved by the Administration.

- .1** a space containing an internal combustion engine of more than 37 kW (50 hp);
- .2** a space containing an oil fired boiler;
- .3** a space containing machinery powered by gasoline or other fuels having a flash point of 43 °C (110 °F) or lower;
- .4** a space containing a fuel tank for gasoline or any other fuel having a flash point of 43 °C (110 °F) or lower;
- .5** a space containing a combustible cargo or vessel's stores inaccessible during the voyage;
- .6** a paint locker; and
- .7** a storeroom containing flammable liquids, including liquors of 80 proof or higher where liquor is packaged in individual containers of 9.5 liters (2.5 gallons) capacity or greater.

10.2 A fixed fire extinguishing system in accordance with regulation **V/10.1** is not required in a space where:-

- .1** the space is open to the atmosphere and the Administration determines that a fixed gas fire extinguishing system would be ineffective; or
- .2** the amount of carbon dioxide gas required in a fixed fire extinguishing system can be supplied by one portable extinguisher or a semi-portable extinguisher meeting the following requirements:

- .1 cylinders shall be installed in a fixed position outside the space protected;
- .2 the applicator shall be installed in a fixed position so as to discharge into the space protected;
- .3 controls shall be installed in an accessible location outside the space protected.

10.3 Except where the space is manned, the following spaces shall be equipped with a fire detecting system of an approved type that is installed to the satisfaction of the Administration:

- .1 a space containing propulsion machinery;
- .2 a space containing an internal combustion engine of more than 37 kW (50 hp);
- .3 a space containing an oil fired boiler;
- .4 a space containing machinery powered by gasoline or any other fuels having a flash point of 43 °C (110 °F) or lower;
- .5 a space containing a fuel tank for gasoline or any other fuel having a flash point of 43 °C (110 °F) or lower; and
- .6 each overnight accommodation space on a vessel with overnight accommodation for passengers.

10.4 When a fixed fire extinguishing system, which is not a portable extinguisher, is installed in a machinery space, it shall be of a type approved by the Administration or equivalent and appropriate to the space to be protected.

Such fixed installation systems in machinery spaces include:-

- .1 low expansion foam;
- .2 medium expansion foam;
- .3 high expansion foam;
- .4 carbon dioxide;
- .5 pressure water spraying; and
- .6 vaporising fluids.

10.5 All grills, broilers, and deep fat fryers shall be fitted with a grease extraction hood to the satisfaction of the Administration.

10.6 A fixed gas fire extinguishing system may protect more than one space. The quantity of extinguishing agent shall be at least sufficient for the space requiring the greatest quantity.

11 Number, Type and location of Portable Fire Extinguishers

11.1 Each portable fire extinguisher on a vessel shall be of an approved type. The minimum number of portable fire extinguishers required on a vessel shall be acceptable to the Administration, and shall be not less than the minimum number required by **Table V.11** and other provisions of this

regulation.

TABLE V.11

Space protected	Minimum No. required	Type extinguisher permitted		
		Class	Medium	Minimum size
Operating Station	1	B-I, C-I	CO2 Dry Chemical ...	1.8 kg (4 lb). 0.9 kg (2 lb)
Machinery Space	1	B-II, C-II located just outside exit.	CO2	6.8 kg (15 lb)
Accommodation Spaces ..	1 for each 232.3 m ² (2,500 square feet) or part thereof).	A-II	Foam Dry Chemical CO2	9.5 l (2.5 gal) 4.5 kg (10 lb) 6.8 kg (15 lb)
Galley, Pantry, Concession Stand	1	A-II, B-II.....	Foam Dry Chemical	9.5 l (2.5 gal) 4.5 kg (10 lb)

11.2 The installation and location of the portable extinguishers shall be to the satisfaction of the Administration.

12 Fire axe

A vessel of 20 m or more (65 feet) in length shall have at least one fire axe located in or adjacent to the primary operating station.

13 Fire bucket

All vessels shall carry at least two 9.5 litre (2½ gallon) buckets and a vessel not required to carry a power driven fire pump by regulation V/7 shall carry at least three 9.5 litre (2½ gallon) buckets, with an attached lanyard satisfactory to the Administration, placed so as to be easily available during an emergency. The words "FIRE BUCKET" shall be stencilled in a contrasting colour on each bucket.

14 Servicing of fixed and portable fire extinguishers

Fixed and portable fire extinguishers shall be serviced annually and the date of service recorded on a tag or label affixed to the extinguisher.

15 Fire Blanket

All ships which have a galley or cooking area shall be provided with a fire blanket which is positioned such that is available for immediate use in the event of a fire in the galley or cooking area.

CHAPTER VI - LIFESAVING EQUIPMENT

1 General Provisions

1.1 Each item of lifesaving equipment carried on board a vessel whether required to be carried or not, shall comply with the technical specifications of the LSA Code, US Coast Guard (for personal floatation devices, (PFD 1)), or where these are not applicable, be approved to an appropriate standard by the Administration.

1.2 Lifesaving appliances on existing vessels shall be in compliance with recognized standards.

2 Number and Type of Survival Craft

2.1 Vessels certified to operate in exposed waters and those making international voyages shall carry lifeboats or liferafts sufficient to accommodate the total number of persons on board.

2.2 Vessels making voyages in coastal waters shall carry lifeboats, liferafts, or buoyant apparatus, and passenger vessels operating solely in protected waters shall carry liferafts or buoyant apparatus, approved in accordance with regulation **I/4**, sufficient to accommodate the total number of persons on board.

2.3 Where the life-saving appliances and their launching appliances, where applicable, are not accessible from both sides of the vessel, additional life-saving appliances shall be fitted as required by the Administration.

2.4 The means and arrangements for embarkation into the survival craft shall be adequate, clearly marked and illuminated and approved by the Administration.

2.5 The manufacturer's model identification, the number given by the approving administration and number of survivors for which the apparatus was approved shall be recorded on a tag or label and affixed to the apparatus.

2.6 The manufacturer's model identification, the number given by the approving administration and number of survivors for which the apparatus was approved shall be recorded on a tag or label and affixed to the apparatus.

3 EPIRB, SART and Radar Reflector

3.1 Each vessel certified to operate in exposed waters, or is on an international voyage and is certified to carry more than 12 passengers shall carry:

- .1** a 406 MHz Emergency Position Indicating Radio Beacon (EPIRB), installed to automatically float free and activate, and
- .2** a 121.5 MHz Search and Rescue Radar Transponder (SART) so stowed that can be easily utilized. The SART need not be carried if the 406 MHz EPIRB required under **VI/3.1.1** has a 121.5 MHz transmitting capability.

3.2 The EPIRB required by **VI/3.1** must be:

- .1** installed in an easily accessible position;

- .2 ready to be manually released and capable of being carried by one person into a survival craft;
- .3 capable of floating free if the ship sinks and of being automatically activated when afloat; and
- .4 capable of being activated manually,
- .5 registered with the appropriate authority.

3.3 Where practicable, as determined by the Administration, all vessels shall be provided with an efficient radar reflector.

4 Distress signals

4.1 All vessels to which the Code applies shall carry:

- .1 six hand held red flare signals.
- .2 six buoyant orange smoke signals.
- .3 six rocket parachute flares.

Provided that vessels operating solely in protected areas may carry six hand held red flare signals, two buoyant orange smoke signals and two rocket parachute flares.

4.2 Distress pyrotechnics shall be stowed in a portable watertight container carried at the operating station.

4.3 Each distress signal shall be clearly marked with the date of manufacture and the date of expiry.

5 Lifebuoys

5.1 A vessel of less than 10 m (32 feet) in length shall carry a minimum of one ring lifebuoy of not less than 610 mm (24 inches) in diameter.

5.2 A vessel of 10 m (32 feet) or more in length, but not more than 20 m (65 feet), shall carry a minimum of two lifebuoys of not less than 610 mm (24 inches) in diameter.

5.3 A vessel of more than 20 m (65 feet) in length shall carry a minimum of three lifebuoys of not less than 762 mm (30 inches) in diameter.

5.4 Each ring life buoy on a vessel shall:

- .1 be readily accessible;
- .2 be stowed in a way that it can be rapidly cast loose;
- .3 not be permanently secured in any way;
- .4 be orange in colour; and
- .5 be marked with the vessels name, identification number and port of registry where applicable.

5.5 At least one of the ring life buoys required by **VI/5.1, VI/5.2 or VI/5.3** shall be fitted with a lifeline. Where more than one ring life buoy is carried one shall not have a lifeline attached.

5.6 For vessels operating between the hours of sunset and sunrise, a lifebuoy light shall be attached to one of the buoys required by **VI/5.1, VI/5.2 or VI/5.3**.

5.7 Each lifeline on a ring life buoy shall:

- .1** be buoyant;
- .2** be of at least 18.5 m (60 feet) in length;
- .3** be non-kinking;
- .4** have a diameter of at least 8 mm (5/16 inch);
- .5** have a breaking strength of at least 510 kg (1,124 pounds); and
- .6** be of a dark colour where synthetic, or of a type certified to be resistant to deterioration from ultraviolet light.

6 Lifejackets

6.1 A number of adult sized life jackets shall be provided equivalent to the maximum number of persons permitted to be carried in a vessel. In addition, a number of child size life jackets shall be carried equal to at least 10% of the total number of persons carried or such greater number as may be required to provide a lifejacket for each child. Children's lifejackets need not be carried where the vessel's Certificate of Inspection is endorsed "*for the carriage of adults only*".

6.2 Each life jacket carried on a vessel certified for operation in exposed waters shall have a life jacket light and a whistle firmly secured by a cord. Each life jacket light shall be securely attached to the front shoulder area of the life jacket.

6.3 Unless otherwise stated in this Chapter, lifejackets shall be stored in convenient places, marked to the satisfaction of the Administration, distributed throughout accommodation spaces.

7 Stowage of survival craft

7.1 Each survival craft shall be:

- .1** stowed in a position that is readily accessible to crew members for launching, or else provided with a remotely operated device that releases the survival craft into launching position or into the water;
- .2** stowed in a way that permits manual release from its securing arrangements;
- .3** ready for immediate use so that crew members can carry out preparations for embarkation and launching in less than 5 minutes;
- .4** provided with means to prevent inadvertent movement of the survival craft in relation to its stowage arrangements;

- .5 stowed in a way that neither the survival craft nor its stowage arrangements will interfere with the embarkation and operation of any other survival craft at any other launching station;
- .6 stowed in a way that any protective covers will not interfere with launching and embarkation;
- .7 fully equipped as required under this Chapter; and
- .8 stowed, as far as practicable, in a position sheltered from breaking seas and protected from damage by fire.

7.2 In addition to the requirements of **VI/7.1**, liferafts shall be secured to the vessel by a painter system with a float-free arrangement which complies with the requirements of paragraph 4.1.6 of the LSA Code.

7.3 In addition to the requirements of regulation **VI/7.1**, buoyant apparatus shall comply with the following:

- .1 each buoyant apparatus shall be attached permanently to the vessel by a painter and float free unit. The weak link used in the float free unit shall have a breaking strain, which is less than that of the painter;
- .2 the means used to attach the float-free link to the vessel shall:
 - .1 have a breaking strength of at least the breaking strength of the painter; and
 - .2 where synthetic, be of a dark colour or of a type certified to be resistant to deterioration from ultraviolet light; and
 - .3 where metal, be corrosion resistant.

7.4 A mechanical, manually operated device to assist in launching a survival craft shall be provided where the survival craft weighs more than 90 kg. It shall also be provided where survival craft requires lifting more than 300 mm (one foot) in a vertical direction to be launched.

8 Special provisions for buoyant apparatus

8.1 Buoyant apparatus shall be of adequate capacity for the number of survivors indicated on its identification tag.

8.2 Where the buoyant apparatus does not have a painter attachment fitting, a means for attaching the painter shall be provided by a wire or line that:

- .1 encircles the body of the device;
- .2 will not slip off;
- .3 has a breaking strength that is at least the strength of the painter; and
- .4 where synthetic, is of a dark colour or is of a type certified to be resistant to deterioration from ultraviolet light.

8.3 Where the vessel carries more than one buoyant apparatus in a group, then each group shall be secured by a single painter.

8.4 The combined weight of each group of buoyant apparatus shall not exceed 180 kg (400 pounds);

8.5 Each buoyant apparatus shall be individually attached to the painter by a line long enough that each buoyant apparatus can float without contacting any other buoyant apparatus in the group. The strength of the float-free link and the strength of the painter shall be determined by the combined capacity of the group of buoyant apparatus.

8.6 Buoyant apparatus shall not be stowed in tiers more than 1.22 m (4 feet) high. When stowed in tiers, the separate units shall be kept apart by spacers.

8.7.1 Each buoyant apparatus shall be fitted with a lifeline, pendants, a painter, paddles, and a light.

8.7.2 The equipment required for buoyant apparatus shall meet the following specifications:

- .1** Lifeline and pendants. The lifeline and pendants shall be as furnished by the manufacturer with the approved buoyant apparatus.
- .2** Painter. The painter shall comply with the requirements of paragraph 4.1.3.2 of the LSA Code.
- .3** Paddles. Each paddle shall be of at least 1.22m (4 feet) in length, buoyant and lashed to the apparatus to which it belongs.
- .4** Light. A light, capable of floating to the satisfaction of the Administration, shall be attached around the body of the buoyant apparatus by a 12-thread manila, or equivalent, lanyard of at least 5.5 m (18 feet) in length.

8A Servicing of life saving appliances

8A.1 Mechanical float free arrangement

8A.1 All mechanical float free arrangements shall be serviced at intervals of not more than 12 months. Where the mechanical float free arrangement is a hydrostatic release unit, it shall be serviced:

- .1** at intervals not exceeding twelve months; however, in cases where it appears proper and reasonable, the Administration may extend this period up to a maximum of eighteen months;
- .2** at an approved service station which is competent to service them, maintains proper servicing facilities and uses only properly trained personnel.

8A.2 Inflatable survival craft, inflatable liferafts and inflatable lifejackets

Every inflatable survival craft, inflatable liferaft and inflatable lifejacket shall be serviced:

- .1** at intervals not exceeding twelve months; however, in cases where it appears proper and reasonable, the Administration may extend this period up to a maximum of seventeen months;

- .2 at an approved service station which is competent to service them, maintains proper servicing facilities and uses only properly trained personnel.

8B Repair of inflatable survival craft

All repair and maintenance of inflatable survival craft shall be carried out in accordance with the manufacturer's instructions. Emergency repairs may be carried out on board the ship; however, permanent repairs should be effected at an approved servicing station.

8C Record of repair and servicing

The owner shall maintain a record of all servicing and repair of the lifesaving appliances for at least eighteen months, or as determined by the Administration. In the case of inflatable liferafts, the date of service shall be recorded on a tag or label which shall be affixed to the liferaft.

9 Survival craft equipment

9.1 Each item of survival craft equipment shall be of good quality, and efficient for the purpose it is intended to serve. Unless otherwise specified in this Chapter, each item of equipment carried, whether required under this Chapter or not, shall be secured by lashings, stored in lockers, compartments, or brackets, or have equivalent mounting or storage arrangements that shall not:

- .1 reduce survival craft capacity;
- .2 reduce space available to the occupants;
- .3 interfere with launching, recovery, or rescue operations; or
- .4 adversely affect seaworthiness of the survival craft.

9.2 Each survival craft shall be fitted with a lifeline, pendants, two paddles, a painter and a light, and such other equipment as the Administration may require taking into account the operation area for which the vessel is certified.

10 Retro-reflective Material

All survival craft, buoyant apparatus, lifebuoys and liferafts shall be marked with retro reflective material as indicated in Annex 1 of IMO Resolution A.658(16)*. The standard of the material used shall be to that prescribed by the Administration.

11 Rescue and retrieval of persons from the water.

11.1 A rescue retrieval system approved by the Administration shall be provided for the retrieval of persons from the water.

11.2 A vessel which is accepted as being able to act as its own rescue boat shall demonstrate the practical effectiveness of the retrieval arrangements provided on board by functional tests carried out under controlled safe conditions to the satisfaction of the Administration.

* IMO Resolution A.658(16) – Use and fitting of retro-reflective materials on lifesaving appliances.

11.3 When a vessel is manned by the helmsman and one crew the demonstration required by the **VI/11.2** shall include retrieval of the crew member from the water (the crewmember can be assumed to be conscious).

CHAPTER VII - MISCELLANEOUS SYSTEMS AND EQUIPMENT

1 General Provisions

The Administration may require navigation, control or communication equipment, in excess of the equipment specifically required by the Code, on a vessel which is of a novel design, operates at high speeds in restricted or high traffic areas, or which operates on extended routes or in remote locations.

2 Navigation Lights, Shapes and Sound Signals

2.1 A vessel shall comply with the requirements of the International Regulations for Preventing Collisions at Sea, 1972 (Collision Regulations).

2.2 Where it can be demonstrated to the Administration that, for a particular vessel, full compliance with the Collision Regulations is impracticable, proposals for an equivalent arrangement may be considered.

3 Charts and Nautical Publications

3.1 A vessel shall carry up-to-date charts, appropriate for the intended voyage, of a large enough scale to enable safe navigation.

3.2 Other Nautical publications such as sailing directions, lists of lights, notices to mariners, tide tables and all other nautical publications to be carried, appropriate to the area of operation, include: as required and approved by the Administration, shall be carried on board and shall be adequate and up to date.

3.3 Extracts from the publications listed in **VII/3.2** for the areas to be transited may be provided instead of the complete publication.

4 Navigation Equipment

4.1 Compass

4.1.1 Except as otherwise provided in **VII/4.1.2** every vessel shall be fitted with a suitable magnetic compass designed for marine use, to be mounted at the primary operating station. The compass shall be illuminated.

4.1.2 The following vessels need not be fitted with a compass:-

- .1** a vessel certified for operation in protected waters
- .2** a non-self propelled vessel; and
- .3** a vessel operating on short restricted routes in coastal waters in daylight.

4.2.1.3 On vessels certified for operation in exposed waters the compass shall be swung at least annually and a deviation card provided near to the compass.

4.2 Radar

4.32.1 A vessel certified to operate in coastal or exposed waters which carries 50 or more passengers shall be fitted with marine radar system for surface navigation approved by the Administration, with a radar screen mounted at the operating station. The radar and its installation shall be suitable for the

intended speed and operating area of the vessel.

4.42.2 A vessel certified to operate in protected waters need not be fitted with a radar where the Administration determines it is not necessary due to the vessel's operating area and local weather conditions.

4.3 Position Fixing Device

4.5 A vessel certified for operation in exposed waters shall be equipped with an electronic position fixing device to the satisfaction of the Administration, capable of providing accurate fixes for the area in which the vessel operates.

4.4 Other Navigation Equipment

A passenger vessel operating in exposed waters shall be provided with

- An echo sounder
- Device for measuring speed and distance through the water.

5 Radio and Signalling Equipment

5.1 All vessels shall be fitted with a marine VHF radio installation. In addition, vessels certified for operation in exposed waters shall be fitted with an INMARSAT-C system or other system appropriate to the sea area designated by the Administration under regulation IV/5 of the International Convention for the Safety of Life at Sea, 1974 as amended (SOLAS), capable of meeting the appropriate requirements of Chapter IV, Part C of SOLAS.

5.2 A durable placard shall be posted next to all radio telephone installations with the emergency broadcast instructions and information, specific to the individual vessel. The emergency broadcast instructions given in **Annex 6**, placed on a placard, shall satisfy the requirement for emergency broadcast instructions in vessels fitted with VHF and MF marine radios not compatible with the requirements of Chapter IV, Part C of SOLAS.

5.3.1 When the electrical supply to radio equipment is from a battery, charging facilities, which are capable of recharging them to the minimum capacity requirements given in **VII/5.3.3** within 10 hours, or a duplicate battery of capacity sufficient for the voyage shall be provided.

5.3.2 The battery electrical supply to radio equipment shall be protected against flooding or swamping as far as practicable and arranged so that radio communications are not interrupted. When the efficiency of the required protection against flooding/swamping cannot be guaranteed, in the case of batteries located below the freeboard deck, an efficiently protected battery supply to the radio equipment shall be provided above the freeboard deck.

5.3.3 When fully charged, the batteries shall provide at least six hours of operation to ensure effective use of the Radio installation.

5.3.4 Each battery shall be installed in accordance with regulation **IV/21**.

5.4 Passenger vessels shall be fitted with a daylight signalling lamp, or other means to communicate by light using a source of power not solely dependent on the ship's power supply. Other vessels operating during the hours of darkness shall be provided with an efficient waterproof electric torch suitable for signalling.

6 Public address systems

- 6.1** This regulation applies to passenger vessels.
- 6.2** Except as noted in **VII/6.5** and **VII/6.6**, each passenger vessel shall be equipped with a public address system.
- 6.3** On a vessel of 20 m (65 feet) or more in length, the public address system shall be a fixed installation and be audible during normal operating conditions throughout the accommodation spaces and all other spaces normally manned by crew members.
- 6.4** A vessel with more than one passenger deck and a vessel with overnight accommodation shall have the public address system operable from the operating station.
- 6.5** On a vessel of less than 20 m (65 feet) in length, a battery powered bullhorn may serve as the public address system where it can be demonstrated to be audible throughout the accommodation spaces of the vessel during normal operating conditions. The bullhorn's batteries shall be continually maintained at a fully charged level by use of a battery charger or other means acceptable to the Administration.
- 6.6** On a vessel of less than 20 m (65 feet) in length carrying less than 50 passengers, a public address system is not required where the Administration is satisfied that a public announcement made from the operating station without amplification can be heard throughout the accommodation spaces of the vessel during normal operating conditions.

7 Mooring and Ground Tackle

- 7.1** A vessel shall be fitted with ground tackle in accordance with **Annex 7**, stowed and ready for deployment, and mooring lines necessary for the vessel to be safely anchored or moored. The ground tackle and mooring lines provided shall be suitable for the size of vessel and waters in which it operates and be acceptable to the Administration. In vessels of less than 12m in length certified to operate only in protected waters, the Administration may permit the carriage of one anchor.
- 7.2** The length of anchor cable attached to an anchor shall be appropriate to the area of operation but generally shall be not less than 4 times the vessel length overall for each of the main and kedge anchors.
- 7.3** When the anchor cable is of rope or wire, there shall be not less than one metre of chain for each metre of vessel length, up to 10 m, between the rope and the anchor.
- 7.4** When an anchor is more than 30 kg, an efficient mechanical means shall be provided for handling the anchor.
- 7.5** There shall be a strong securing point on the foredeck and a fairlead or roller at the stem head, which can be closed over the cable.

8 First Aid Kit

- 8.1** A vessel shall carry a first aid kit approved by the Administration. The kit shall consist of a watertight container capable of holding all the items specified in **Annex 8**, with directions for use, stowed in a suitable container that is marked, "First Aid Kit". A first aid kit shall be easily visible and readily available to the crew.
- 8.2** A first aid kit, which complies with the provisions of **Annex 8**, shall be accepted as satisfying the requirements of **VII/8.1**.

9 Cooking and Heating

9.1 Cooking and heating equipment shall be suitable for marine use and shall be designed and installed to the satisfaction of the Administration.

9.2 Gasoline shall not be used for cooking, heating or lighting on board a vessel.

9.3 Subject to **VII/9.4**, fire places or other heating and cooking equipment with open flames shall not be used on board a vessel.

9.4 Liquefied and non-liquefied gases may be used as cooking fuels where the installation of such system is to the satisfaction of the Administration. Open gas flame appliances, other than cooking stoves, domestic refrigerators or water heaters are not permitted. Spaces containing any such stoves or water heaters shall have adequate ventilation to remove fumes and possible gas leakage to a safe space. All pipes conveying gas from a container to an appliance shall be of steel or other appropriate material. Automatic safety gas shut-off devices shall be fitted to operate on loss of pressure in the gas main pipe or flame failure on any appliance.

10 Pollution Prevention Equipment and Procedures

10.1 All oily waste shall be retained on board for proper disposal ashore. Vessels fitted with approved oily water separators may discharge into the sea when the content of the effluent without dilution does not exceed 15 parts per million.

10.2 Garbage shall be disposed of in accordance with the following:

- .1** disposal into the sea of the following is prohibited:
 - (a)** all plastics, including but not limited to synthetic ropes, synthetic fishing nets and plastic garbage bags; and
 - (b)** all other garbage, including paper products, rags, glass, metal, bottles, crockery, dunnage, lining and packing materials;
- .2** except as provided in **.3**, disposal into the sea of food wastes shall be made as far as practicable from land, but in any case not less than 12 nautical miles from the nearest land;
- .3** disposal of food wastes which have been passed through a comminuter or grinder shall be made as far as practicable from land, but in any case not less than 3 nautical miles from the nearest land. Such comminuted or ground food wastes shall be capable of passing through a screen with openings no greater than 25mm; and
- .4** garbage mixed with other discharges having more stringent disposal or discharge requirements.

10.3 Regulations **VII/10.1** and **VII/10.2** shall not apply to:

- .1** discharges or disposals into the sea necessary for the purpose of securing the safety of the vessel and those on board or saving life at sea; or
- .2** the discharge or escape of oil, waste or garbage into the sea resulting from damage to the vessel or its equipment provided all reasonable precautions have been taken before or after the occurrence of the damage for the purpose of preventing or minimising the discharge or escape.

10.4 A new vessel with toilet facilities capable of discharging waste to the sea shall be fitted with a holding tank of suitable size to accommodate the total number of persons on board for the duration of the voyage. Guidance on the size of the holding tank required is given in **Annex 9**.

10.5 A sewage treatment plant which meets the operational requirements given in the Recommendation on International Effluent Standards and Guidelines for Performance Tests for Sewage Treatment Plants adopted by the Marine Environment Protection Committee of the International Maritime Organization by Resolution MEPC.2(VI) may be fitted, in lieu of the holding tank required by **VII/10.4**

CHAPTER VIII - OPERATIONAL REQUIREMENTS

PART A - OPERATIONAL REQUIREMENTS

1 General Provisions

1.1 A vessel shall be operated in accordance with applicable legislation and in such a manner as to afford adequate precaution against hazards, which might endanger the vessel, its passengers and cargo.

2 Marine Casualties

2.1 The owner, agent, master or person in charge of a vessel involved in a marine casualty shall give notice as soon as possible to the Administration whenever the casualty involves any of the following:

- .1** any grounding or collision which creates a hazard to navigation, the environment or the safety of the vessel;
- .2** loss of main propulsion, primary steering or any associated component or control system, the loss of which causes a reduction of the manoeuvring capabilities of the vessel;
- .3** an occurrence materially and adversely affecting the vessel's seaworthiness or fitness for service or route, including but not limited to fire, flooding, failure of or damage to fixed fire extinguishing systems, lifesaving equipment, auxiliary power generating equipment or bilge pumping systems;
- .4** loss of life;
- .5** injury which requires professional medical treatment beyond first aid and, in the case of a person engaged or employed on board a vessel in commercial service, which renders the individual unfit to perform routine vessel duties; or
- .6** an occurrence resulting in damage to property estimated to be in excess of US \$10,000, including the cost of labour and material to restore the property to service condition.

2.2 The notice required by **VIII/2.1** shall include the name and identity number of the vessel involved, the name of the vessel's owner or agent, the nature and circumstances of the casualty, the locality in which it occurred, the nature and extent of injury to persons and the damage to property.

2.3 In addition to the notice required by **VIII/2.1**, the owner, master, agent or person in charge of the vessel shall, within 3 days, provide a report in writing to the Administration. The report shall contain the information required by **VIII/2.2** and where submitted without delay after the occurrence of the casualty, suffices as the notice required by **VIII/2.1**.

3 Logbook

3.1 Every vessel certified for operation on exposed waters on an international voyage shall have a Logbook on board. The master shall make or have made in the Logbook the following entries:

- .1** when a marine casualty occurs, a statement about the casualty and the circumstances under which it occurred, made immediately after the casualty when practicable to do so;

- .2 details of the voyage, including course and weather conditions at least every 4 hours, and drills tests required by this Chapter;
- .3 each death on board and the cause of death;
- .4 the name of each seaman who ceases to be a crew member, except by death, with the time, place, manner and the cause why the seaman ceased to be a crew member; and
- .5 details of drills and training required by regulations **VIII/10** and **VIII/11**.

3.2 The log entry required by **VIII/3.1.2** in respect of abandon ship man overboard and fire drills and training shall include the following information.

- .1 date of the drill and training; and
- .2 general description of the drill scenario and training topics.

4 Miscellaneous Operating Requirements

4.1 The master shall ensure the vessel is navigated at all times in a safe and controlled manner. The master shall also ensure that all of the provisions of the Certificate of Inspection are adhered to; however, the master may divert from the route prescribed in the Certificate of Inspection or take such other steps as are deemed necessary and prudent to assist vessels in distress or for other similar emergencies.

4.2 The master shall ensure that applicable stability requirements are adhered to at all times.

4.3 The master shall ensure that steering gear, controls and communication systems are tested before every voyage commences and prior to entering harbour.

4.4 All hatches and openings in the hull of a vessel shall be kept tightly closed except when being used. All watertight doors in subdivision bulkheads shall be kept tightly closed during the navigation of the vessel except when being used for transit between compartments.

4.5 A vessel shall not take on fuel having a flashpoint of 43.3⁰C (110⁰F) or lower, when passengers are on board.

4.6.1 A passenger vessel shall not carry dangerous goods except when allowed to do so under the International Maritime Dangerous Goods Code (IMDG Code).

4.6.2 The requirements of Chapter VII of SOLAS 74 shall apply to the carriage of dangerous goods classified in regulation 2 of that Chapter, which are carried in vessels in packaged form or in solid form in bulk as appropriate.

4.6.3 The Administration may apply the requirements of **VIII/4.6.2** according to the service characteristics of the vessel and the risks associated with its operations, taking into account the safety of persons on board, the safety of property at sea and the protection of the marine environment from pollution.

4.7 Whenever an automatic pilot is used the master shall ensure that:

- .1 it is possible at all times to immediately establish manual control of the vessel's steering;

- .2 a competent person is ready at all times to take over steering control; and
- .3 the changeover from automatic to manual steering and vice versa is made by, or under the supervision of, the master or the senior officer on watch.

PART B - PREPARATIONS FOR EMERGENCIES

5 Record of Passengers

5.1 The owner, charterer, managing operator or master of a vessel making a voyage in exposed or coastal waters shall keep an accurate record of all persons, which embark on and disembark from the vessel, including the names and gender, distinguishing between adults, children and infants.

5.2 The owner, charterer, managing director or master of a vessel on any other type of voyage shall keep a correct, written count of all passengers, which embark on and disembark from the vessel. Prior to departing on a voyage, the passenger count shall be deposited ashore in a well marked location or with a representative of the owner or managing operator of the vessel.

6 Passenger Safety

6.1 Before getting underway on a voyage where passengers are carried, the master of a vessel shall ensure that suitable public announcements are made informing all passengers of the following, as applicable to the vessel's operations and arrangement:

- .1 a general explanation of emergency procedures;
- .2 the location of emergency exits and survival craft embarkation areas;
- .3 the stowage location of lifejackets;
- .4 the proper method of putting on and adjusting lifejackets of the type carried on the vessel including a demonstration of the proper donning of a lifejacket;
- .5 the location of the instruction placards for lifejackets and other lifesaving devices; and
- .6 that all passengers will be required to wear lifejackets when possible hazardous conditions exist, as directed by the master.

6.2 As an alternative to an announcement that complies with **VIII/6.1**, the master or other designated person may:

- .1 prior to getting underway, deliver to each passenger or, on a vessel that does not carry vehicles and that has seats for each passenger, place near each seat, a card or pamphlet that has the information listed in **VIII/6.1.1 to VIII/6.1.6**; and
- .2 make an abbreviated announcement consisting of:
 - .1 a statement that passengers should follow the instructions of the crew in an emergency;
 - .2 the location of lifejackets; and
 - .3 that further information concerning emergency procedures including the

donning of lifejackets, location of other emergency equipment, and emergency evacuation procedures are located on the card or pamphlet that was given to each passenger or is located near each seat.

6.3 Ferries operating on short runs of less than 15 minutes may substitute bulkhead placards or signs for the announcement required in **VIII/6.1** and **VIII/6.2** where the Administration determines that the announcements are not practical due to the vessel's unique operation.

6.4 On a vessel on a voyage of more than 12 hours duration, passengers shall be requested to put on lifejackets and go to the appropriate embarkation station during the safety orientation. Where only a small number of passengers embark at a port after the original muster has been held, these passengers shall be given the passenger safety orientation required by **VIII/6.1** or **VIII/6.2** if another muster is not held.

6.5 The master of a vessel shall require passengers to wear lifejackets when possible hazardous conditions exist, including, but not limited to:

- .1** when transiting hazardous bars and inlets;
- .2** during severe weather;
- .3** in event of flooding, fire or other events which may possibly call for evacuation; and
- .4** when the vessel is being towed.

6.6 Sufficient emergency instructions shall be posted to enable passengers to know what action to take in the event of an emergency.

6.7 Sufficient instructions on how to don lifejackets shall be posted to enable passengers to undertake this action in the event of an emergency.

7 Emergency Instructions

7.1 The master and crew of a vessel shall be familiar with the content of emergency instructions containing the actions to be taken in the event of fire, heavy weather, or man overboard conditions. Such instructions shall be displayed at the operating station.

7.2 Except when in the opinion of the Administration the operation of a vessel does not present any of the hazards listed, the emergency instruction placard shall contain at least the applicable portions of the "Emergency Instructions" listed in regulation **VIII/8**. The emergency instructions shall be designed to take account of the particular equipment, arrangement, and operation of each individual vessel.

7.3 Where the Administration determines that there is no suitable mounting surface aboard the vessel, the emergency instructions need not be posted but shall be carried aboard the vessel and be available to the crew for familiarization.

8 Recommended Emergency Instructions Format

An emergency instruction placard containing the following information will satisfy the requirements of regulation **VIII/7**.

EMERGENCY INSTRUCTIONS

Rough weather at sea, crossing hazardous bars or flooding

1. Close all watertight and weathertight doors, hatches, and airports to prevent taking water aboard.
2. Keep bilges dry to prevent loss of stability due to water in bilges. Use power driven bilge pump, hand pump, and buckets to dewater.
3. Arrange fire pumps to be use as bilge pumps where permitted.
4. Check all intake and discharge lines, which penetrate the hull, for leakage.
5. Passengers shall remain seated and evenly distributed as directed by the master.
6. Passengers shall wear life jackets when instructed by the master.
7. Where assistance is needed follow the procedures on the emergency broadcast placard posted by the radiotelephone.
8. Prepare survival craft (life floats, (inflatable) rafts, (inflatable) buoyant apparatus, boats) for launching.
9. Instructions to abandon the vessel shall not be given unless in the opinion of the master the risk of persons remaining on board exceeds the risk of evacuating the vessel.

Man overboard

1. Throw a life buoy overboard as close to the person as possible.
2. Post a lookout to keep the person overboard in sight.
3. Launch the rescue boat and manoeuvre to pick up person in the water, or manoeuvre the vessel to pick up the person in the water.
4. Have a crew member put on lifejacket, attach a safety line to him or her, and have him or her stand by ready to jump into the water to assist the person overboard if necessary.
5. Where person is not immediately located, notify Coast Guard and other vessels in vicinity by radiotelephone.
6. Continue search until released by Coast Guard or where the master considers it impracticable to continue the search..

Fire

1. Cut off air supply to fire – close items such as hatches, ports, doors, ventilators, and louvers, and shut off ventilation system.
2. Cut off electrical system supplying affected compartment if possible.

3. Where safe, immediately use portable fire extinguishers at base of flames for flammable liquid or grease fires or water for fires in ordinary combustible materials. Do not use water on electrical fire.
4. Where fire is in machinery spaces, shut off fuel supply and ventilation and activate fixed extinguishing system if installed.
5. Manoeuvre vessel to minimize effect of wind on fire.
6. Where unable to control fire, immediately notify the Coast Guard and other craft in the vicinity by radiotelephone.
7. Move passengers away from fire, have them put on lifejackets, and where necessary, prepare to abandon the vessel.

9 Emergency Station Bill

9.1 On a vessel of more than 20 m (65 feet) in length required to have more than four crew members at any one time, including the master, a station bill shall be posted by the master.

9.2 The station bill required by **VIII/9.1** shall set forth the special duties and duty station of each crew member for various emergencies. The duties shall, as far as possible, be consistent with the regular work of the individual. The duties shall include at least the following and any other duties necessary for the proper handling of a particular emergency:

- .1 the closing of hatches, airports, watertight doors, vents, scuppers, and valves for intake and discharge lines that penetrate the hull, the stopping of fans and ventilating systems, and the operating of all safety equipment;
- .2 the preparing and launching of survival craft and rescue boats;
- .3 the extinguishing of fire; and
- .4 the mustering of passengers including the following:
 - .1 warning the passengers;
 - .2 assembling the passengers and directing them to their appointed stations; and
 - .3 keeping order in the passageways and stairways and generally controlling the movement of the passengers.

9.3 The station bill shall be posted at the operating station and in a conspicuous location in each crew accommodation space.

10 Abandon Ship and Man Overboard Drills and Training

10.1 The master shall conduct sufficient drills and give sufficient instructions to make sure that all crew members are familiar with their duties during emergencies that necessitate abandoning ship or the recovery of persons who have fallen overboard.

10.2 Each abandon ship drill shall include:

- .1 summoning the crew to report to assigned stations and prepare for assigned duties;

- .2 summoning passengers on a vessel on an overnight voyage to muster stations or embarkation stations and ensuring that they are made aware of how the order to abandon ship will be given;
- .3 checking that lifejackets are correctly worn; and
- .4 instructions on the automatic and manual deployment of survival craft.

10.3 Each abandon ship drill shall, as far as practicable, be conducted as if there were an actual emergency.

10.4 Each rescue boat where provided, shall be launched with its assigned crew aboard and maneuvered in the water as if during an actual man overboard situation:

- .1 once each month, where reasonable and practicable; but
- .2 at least once within a 3 month period before the vessel gets underway with passengers.

11 Fire Fighting Drills and Training

11.1 The master shall conduct sufficient fire drills to make sure that each crew member is familiar with his or her duties in case of a fire.

11.2 Each fire drill shall include:

- .1 summoning the crew to report to assigned stations and to prepare for and demonstrate assigned duties;
- .2 summoning passengers on a vessel on an overnight voyage to muster or embarkation stations; and
- .3 instruction in the use and location of fire alarms, extinguishers, and any other fire fighting equipment on board.

11.3 Each fire drill shall, as far as practicable, be conducted as if there were an actual emergency.

12 Nothing in the emergency instructions or a station bill required by this Chapter exempts any licensed individual from the exercise of good judgement in an emergency situation.

13 Markings Required

13.1 The following marking is required:

- .1 all lifesaving and firefighting equipment shall be marked with the vessel's identity number;
- .2 all escape hatches and other emergency exits used as means of escape shall be marked on both sides in clearly legible letters at least 50mm (2 inches high): "EMERGENCY EXIT, KEEP CLEAR", unless such markings are deemed unnecessary by the Administration;
- .3 remote fuel shutoff stations shall be marked in clearly legible letters at least 25mm (1 inch) high indicating purpose of the valve and direction of operation; and

- .4 watertight doors and watertight hatches shall be marked on both sides in clearly legible letters at least 25mm (1 inch) high: "WATERTIGHT DOOR - KEEP CLOSED" or "WATERTIGHT HATCH - KEEP CLOSED", unless such markings are deemed unnecessary by the Administration.

13.2 Complete but simple instructions for the operation of a fixed gas fire extinguishing system shall be located in a conspicuous place at or near each pull box and stop valve control and in the space where the extinguishing agent cylinders are stored. Emergency signs and warnings shall be to the satisfaction of the Administration.

14 Operational Readiness, Maintenance and Inspection of Lifesaving Equipment

Each launching appliance and each survival craft and rescue boat on a vessel shall be in good working order and ready for immediate use before the vessel leaves port and at all times when the vessel is underway. Each deck where survival craft or rescue boats are stowed or boarded shall be kept clear of obstructions that could interfere with the boarding and launching of the survival craft or rescue boat. All lifesaving equipment shall be maintained in accordance with the manufacturer's instructions and to the satisfaction of the Administration.

15 Instruction manuals, documentation, signs/notices and language used

15.1 The owner shall ensure that instruction manuals are available for all equipment and machinery onboard the ship as required by the Administration.

15.2 All instruction manuals, signs, notices, plans and documents relating to the safety and operation of the ship and its machinery and equipment shall be in the official language of the flag State and, where applicable, the working language of the crew.

CHAPTER IX - LICENCING OF BOATMASTERS AND ENGINEERS, MANNING AND HOURS OF WORK

PART A - LICENCES

1 Master

1.1 A commercial vessel shall carry in command a person who is qualified as follows:

- .1** he or she is the holder of a licence issued by the Administration under regulation **IX/3** stating that he or she is qualified to have command of such a vessel;
- .2** the licence is in force and is of a grade appropriate in respect to the waters in which the vessel is being navigated, the size of the vessel and the number of passengers carried; and
- .3** the vessel is in an area specified in the licence as one in which a vessel may be navigated under the command of the holder; or

1.2 The holder of a certificate of competency as a Master issued in accordance with the provisions of the STCW Convention may command any vessel under the Code, subject to any limitations of that certificate of competency.

2 Engineers

2.1 A commercial vessel fitted with main propulsion machinery of up to 750 kW(1000 hp), shall where an engineer is required by the Administration, carry as engineer a person who is qualified as follows:

- .1** he or she is the holder of a licence issued by the Administration under regulation **IX/3** stating that he or she is qualified to be in charge of the main and auxiliary machinery of such a vessel;
- .2** the licence is in force and is of a grade appropriate in respect both of the waters in which the vessel is being navigated; and
- .3** the vessel is in an area specified in the licence as one in which a vessel may be operated under the charge of the holder; or

2.2 The holder of a certificate of competency as an engineer officer issued in accordance with the provisions of the STCW Convention may be carried as engineer in any vessel under the Code, subject to any limitations of that certificate of competency.

2.3 Except as authorised by the Administration, vessels having main propulsion machinery of a power of 750kW (1000hp) and over shall carry engineers qualified in accordance with the STCW Convention.

2 A Crew

2 A 1. A commercial vessel required by the Administration to carry crew, in addition to a Master and Boat Engineer, shall carry as such crew, persons who hold the additional qualifications identified in section 1.2 of **Annex 11** of the Code.

2A 2: A passenger vessel shall carry Masters, Boat Engineers and Crew, as required by the Administration, who have completed the training specified in section A-V/3, paragraphs, 1, 4 and 5 of the Seafarers, Training, Certification and Watchkeeping Code, (STCW Code) as appropriate.

3 Licence issue, standards and conditions

3.1 The Administration may issue licences as Boatmaster or Boat Engineer, as appropriate to persons who meet the requirements of this Regulation. The form of the Boatmaster and Boat Engineer licences are given in **Annex 10**.

3.2 An application for a licence under this regulation shall be made in such form as the Administration may from time to time specify.

3.3 Subject to **IX/3.4**:

- .1** the standards of competence to be attained and the conditions, including conditions as to medical fitness, to be satisfied by a person in order for a licence to be issued to him under the Code;
- .2** any exceptions applicable with respect to any such standards or conditions;
- .3** the manner in which the attainment of any such standards or the satisfaction of any such conditions is to be evidenced; and
- .4** the conduct of any examinations and the conditions of admission to them;

shall be those specified in regulations **IX/5** to **IX/7** and **IX/9** to **IX/11** or those which may from time to time be specified by the Administration in a Shipping Notice.

3.4 Notwithstanding that an applicant for a licence under this regulation complies with the standards and satisfies the conditions specified by the Administration, the Administration shall not issue such a licence to the applicant unless it is satisfied, having regard to all the relevant circumstances, that the applicant is a fit person to be the holder of such a licence.

4 Grades and area restrictions of Boatmaster Licences

4.1 A licence as a Master issued under regulation **IX/3** shall bear the title “Boatmaster Licence” and shall be of one of the following grades, which shall be stated in the licence-

- Boatmaster Licence, Grade 1
- Boatmaster Licence, Grade 2
- Boatmaster Licence, Grade 3.

4.2 The grade of licence appropriate in respect of a vessel when being navigated in waters specified in column (1) of **Table IX/4.2**, being of the size or type specified in relation to those waters in column (2) of the Table shall be either that specified in relation to those waters and that size or type of vessel in column (3) of the Table or, where the grade so specified is 2 or 3, a higher grade than that so specified:

TABLE IX/4.2

(1) Waters	(2) Size and type of vessel	(3) Minimum Grade of Licence
Protected	Open Boat (<i>daylight only</i>)	3
	<24m	2
Coastal	Open Boat (<i>daylight only</i>)	3
	<12m passenger	2
	<24m other than passenger	2
	12 - 24m passenger	1
Exposed	All vessels	1

4.3 Where a vessel, the master of which is required to hold a Grade 2 licence, is to be operated more than twenty miles from a safe haven, a navigation endorsement is required. The syllabus is a practical test in chartwork and electronic aids to navigation.

4.4 Where a vessel, the master of which is required to hold a licence, has sails as its principal means of propulsion a sail endorsement is required. The requirement for a sail endorsement is a practical test on boat handling as detailed in **Annex 11-1.1**.

4.5 A Boatmaster licence of any grade shall be subject to such restriction as the Administration may determine as to the area or areas in which a vessel may be navigated under the command of the holder; and every such restriction shall be stated in the licence.

5 Requirements for obtaining a Boatmaster Licence

5.1 In order to obtain a Boatmaster Licence Grade 3 an applicant shall -

- .1** be eighteen years of age or over;
- .2** have submitted a valid medical certificate in compliance with **IX/14**;
- .3** have completed a course of ten hours of practical instruction under a licenced Boatmaster in sail or power vessels of appropriate size;
- .4** produce documentary evidence of having obtained the additional qualifications stated in **Annex 11-1.2**; and
- .5** have passed an examination for Boatmaster Grade 3.

5.2 In order to obtain a Boatmaster Licence Grade 2 an applicant shall -

- .1** be twenty years of age or over;
- .2** have submitted a valid medical certificate;
- .3** have completed a course of ten hours of practical instruction under a licenced operator in sail or power vessels of appropriate size;
- .4** produce documentary evidence of having obtained the additional qualifications stated in **Annex 11-1.2**; and

.5 have passed the examination for Boatmaster Grade 2.

5.3 In order to obtain a Boatmaster Licence Grade 1 an applicant shall -

.1 be twenty one years of age;

.2 have completed a course of ten hours of practical instruction under a licenced operator in sail or power vessels of appropriate size;

.3 have submitted a valid medical certificate;

.4 produce documentary evidence of having obtained the additional qualifications stated in **Annex 11-1.2**; and

.5 have passed the examination for Boatmaster Grade 1.

6 Practical Instruction

Where an applicant is required to have had practical instruction this will be construed as his or her having enough experience to demonstrate proper boat handling skills in whatever craft or vessel the experience may have been given. However, it should be borne in mind that the prospective licence holder needs to demonstrate adequate knowledge of the methods of controlling, handling and directing vessels in emergencies, on the vessels, which he will be entitled to command.

7 Examination for Boatmaster Licences

7.1 A Boatmaster examination for Grades 2 and 3 consists of two parts. The first of which is an oral examination in which applicants will be tested on their knowledge of safety, navigation, rule of the road and seamanship subjects and also how they respond to certain emergency situations. The second part consists of a practical test carried out on the size of vessel for which the applicant needs a licence. This test requires applicants to demonstrate their ability to handle the vessel in various circumstances.

7.2 The Boatmaster examination for Grade 1 consists of three parts. The first part of which is an oral examination in which applicants will be tested on their knowledge of safety, rule of the road and seamanship subjects and also how they respond to certain emergency situations. The second part consists of a practical test in chartwork and the use of electronic aids to navigation. The third part is a practical test carried out on a vessel of 12m - 24m in length. This test requires applicants to demonstrate their ability to handle the vessel in various circumstances.

7.3 An applicant passing only one part of the examination will be allowed to retain the pass in that part for a period of one year subject to the applicant being the holder of a valid medical fitness certificate when re-sitting the other part. Details of the syllabus for each grade are contained in **Annex 11-1.1**.

8 Grade and Area Restrictions of Boat Engineer Licences

8.1 A licence as engineer issued under regulation **IX/3** shall bear the title “Boat Engineer Licence” and shall be of one of the following grades, which shall be stated in the licence.

Boat Engineer Licence, Grade 1

Boat Engineer Licence, Grade 2

8.2 The grade of licence appropriate in respect of a vessel when being operated in waters specified in column (1) of **Table IX/8.2**, being of the size specified in relation to those waters in column (2) of the Table shall be either that specified in relation to those waters and that size of vessel in column (3) of the Table or, where the grade so specified is 2, a higher grade than that so specified:

TABLE IX/8.2

(1) Waters	(2) Size of vessel	(3) Minimum Grade of Licence
Protected	<24m	no licence required
Coastal	15 - 24m	2
Exposed	<24m	1

8.3 A Boat Engineer licence of any grade shall be subject to such restriction as the Administration may determine as to the area or areas in which a vessel may be operated under the charge of the holder; and every such restriction shall be stated in the licence.

8.4 A person required to hold a Boat Engineer Licence on a passenger vessel must also have completed six months service whilst holding the appropriate certificate.

9 Requirements for obtaining a Boat Engineer Licence

In order to obtain a Boat Engineer Licence an applicant shall -

- .1 be eighteen years of age or over;
- .2 have completed an approved course on the repair and maintenance of engines and associated systems on seagoing vessels;
- .3 have submitted a valid medical certificate;
- .4 produce documentary evidence of having obtained the additional qualifications stated in **Annex 11-1.2.1**; and
- .5 have passed the examination for Boat Engineer.

10 Approved Course

10.1 An approved course is a course approved by the Administration, which covers the syllabus given in **Annex 11-2**. A Certificate of Attendance will be given by the course organisers to persons satisfactorily completing the course.

10.2 Persons who are able to demonstrate to the satisfaction of the Administration that they have appropriate engineering experience may be granted an exemption from the requirement to attend an approved course.

11 Examination for Boat Engineer Licences

11.1 A Boat Engineer examination for Grades 1 and 2 consists of an oral examination in which applicants shall be tested on their knowledge of marine engines, propulsion systems, auxiliary machinery systems outboard engines, safe working practices and how the candidate responds to certain emergency situations.

11.2 The examination for a Boat Engineer Licence shall be based on the syllabus given in **Annex 11-2** at a level appropriate to the Grade of Licence applied for and its range of application.

11.3 A candidate who is unsuccessful in the examination shall resit the entire examination.

12 Existing licences

12.1 Subject to **IX/12.2**, the standards of competence to be attained and the conditions to be satisfied by the holder of an existing licence to operate commercial vessels in order for a licence to be issued to that person under this Chapter, shall be such standards and conditions as were to be satisfied by that person in order for the existing licence to be issued. Accordingly, the Administration shall on the application of the holder of an existing licence issue to that person a licence under this Chapter; and the licence shall -

- .1** be of the grade which is appropriate in respect of -
 - .1** a vessel when being navigated/operated in waters in the area or areas stated in the existing licence as the area or areas of operation; and
 - .2** the size of vessel which in the period of 12 months before the coming into force of the Code was navigated/operated in that area under the command or charge of the holder of the existing licence; and
- .2** state the area or areas in which a vessel may be navigated/operated under the command or charge of the holder, as the area or areas stated in the existing licence as the area or areas of operation.

12.2 A person to be issued a licence under **IX/12.1** must hold the additional qualifications identified in **Annex 11 paragraph 1.2** and have appropriate knowledge of the Code, to the satisfaction of the Administration.

13 Period of Validity and Renewal of Licence

13.1 Licences shall be subject to re-validation every three years for persons up to 63 years of age and annually for persons 63 years of age and over. Re-validation will be subject to the holder having proof that he or she has had, in the case of persons up to 63 years of age, at least 45 days service and in the case of persons 63 years of age and over, at least 15 days service, in vessels for which the licence is valid during that time. Revalidation is also subject to the submission of a medical certificate in accordance with regulation **IX/14**.

13.2 Applicants unable to provide proof of service required by **IX/13.1** shall satisfy the Administration of continued professional competence through test or re-examination.

13.3 A licence shall only remain valid so long as the person to whom it is issued holds a valid medical fitness certificate.

14 Medical Fitness Certificate

A medical fitness certificate in accordance with the Shipping Medical Examination Regulations shall be submitted with the initial application for a Boatmaster or Boat Engineer licence and for the re-validation of a licence. To obtain this an applicant is required to undergo a medical examination and have an eye sight test for colour and vision in accordance with the provisions of the Medical Examination Regulations.

15 Record and surrender of licences

15.1 The Administration shall make and, during the period of the licence, retain a copy of every licence issued under this Chapter.

15.2 A record of-

- .1** every licence issued under this Part;
- .2** every suspension, cancellation or alteration of and any other matter affecting such a licence;

shall be kept, in such manner as the Administration may require, by the Registrar of Shipping or by such other person as the Administration may direct.

PART B - HOURS OF WORK

16 Working Hours

16.1 References to a person being on duty are references-

- .1** in the case of a master who has command of a vessel in the course of his employment, to being on duty, whether for the purpose of having the command of a vessel to which this Chapter applies or for other purposes, in the employment of the person who employs him in that employment or in any other employment under that person; and
- .2** in the case of a master who has command of a vessel for the purposes of a trade or business carried on by him, to having command of a vessel to which this Chapter applies for the purposes of that trade or business or being otherwise engaged in work for the purposes of that trade or business, being work in connection with such a vessel or the passengers carried by it.

16.2 A master shall so far as is reasonably practicable ensure that he or she is properly rested when first going on duty on any working day.

16.3 Subject to **IX/16.7**, the working day of a master shall not exceed 16 hours.

16.4 Subject to **IX/16.7**, a master shall not on any working day con a vessel or vessels to which the Code applies for periods amounting in the aggregate to more than 10 hours.

16.5 Subject to **IX/16.7**, where on any working day a master has been on duty-

- .1** for a period of 6 hours and the end of that period does not mark the end of the working day; or
- .2** for periods amounting in the aggregate to 6 hours and there has not been between any of those periods an interval of not less than 30 minutes in which the master was able to obtain rest and refreshment and the end of the last of those periods does not mark the end of the working day;

there shall be an interval for rest -

- .1** as respects the period mentioned in **.1** above, at the end of that period; or

- .2 in the case of the periods mentioned in .2 above, at the end of the last of those periods.

16.6 Subject to **IX/16.7** there shall be, between any two successive working days of a master, an interval for rest which shall not be of less than 8 hours; and, in the case of a master who has command of a vessel in the course of his employment, a period of time shall not be treated as not being an interval for rest by reason only that he may be called upon to report for duty if required.

16.7 Where the Administration considers that it would be appropriate to grant an exemption from all or any of the requirements of **IX/16.3** to **IX/16.6**, it may on such terms, if any, as maybe specified grant such an exemption; and, subject to giving reasonable notice, the Administration may alter or cancel an exemption so granted.

16.8 The provisions of **IX/16.3** to **16.6** apply to vessels operating in protected and coastal waters. The working hours of seafarers on vessels operating in exposed waters shall be determined by the relevant provisions of the International Convention on Standards of Training, Certification and Watchkeeping for Seafarers, 1978 as amended.

PART C - MANNING

17 Additional crew

17.1 It shall be the duty of an owner of a vessel to which this regulation applies to notify in writing to the Administration -

- .1 the geographical limits within which he proposes that the vessel be navigated;
- .2 the number of crewmen in addition to the master whom the owner considers it appropriate that the vessel should carry when being navigated within the geographical limits so notified; and
- .3 whether the owner considers it appropriate that, when the vessel is being so navigated, a crewman should be the holder of a licence of any grade under the Code.

17.2 The Administration may approve -

- .1 the number of crewmen notified in accordance with **IX/17.1.2**; and
- .2 that a crewman is to be, or that no crewman need be, the holder of a licence in accordance with a notification under **IX/17.1.3**.

17.3 A vessel to which this regulation applies shall not proceed on a voyage or excursion unless-

- .1 the Administration has been notified in accordance with **IX/17.1.1**;
- .2 the Administration has given an approval in accordance with **IX/17.2**; and
- .3 the manning of the vessel is in accordance with the approval given under **IX/17.2**.

17.4 Any approval given under this regulation shall be in writing and shall specify the date on which it takes effect and the conditions, if any, on which it is given.

Annex 2

SIMPLIFIED STABILITY TEST PROCEDURE

(SCV Code III/8)

Page 1 of 8

Name of Vessel ----- Documentation No. ----- Date -----

Owner/Representative ----- Inspector -----

Location ----- Wind: Relative Direction ----- Vel -----kts

Mooring Arrangement -----

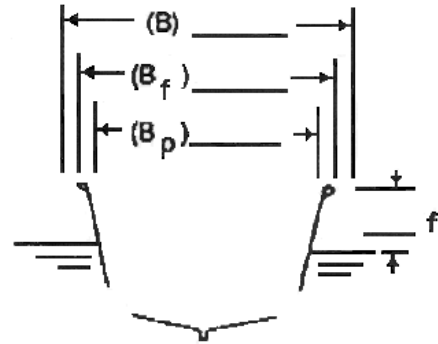
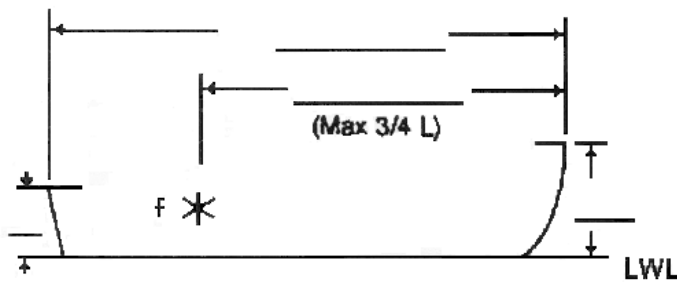
Route ----- Check One Exposed .. Coastal Protected**Indicate on above Sketch**

- 1) Profile of sheer line.
- 2) Length overall (L)
- 3) Station for measuring Reference Freeboard (f) above load waterline (LWL), located in way of least freeboard or at a point $\frac{3}{4}$ (L) from the stem if the least freeboard is aft of this point..
- 4) Freeboard at bow
- 5) Freeboard at stern*.

Indicate on above Sketch

- 1) Round or vee bottom
- 2) Maximum beam (B) to outside of shell; greater or equal to (B_f).
- 3) Maximum beam (B_p) accessible to passengers.
- 4) Maximum beam (B_f) on deck in way of Reference Station.
- 5) Reference Freeboard (f), height of sheer line above the LWL, in way of Reference Station.
- 6) Height of weather deck (including cockpit deck, if any) above load waterline in way of Reference Station.

All of the above measurements are to be taken in the loaded condition without list (III/8.6). Measurements for (L), (B), and (B_p) are to exclude rub rails. If the vessel carries passengers on diving excursions, the total weight of the diving gear must be included in the loaded condition. If the vessel has a cockpit or well deck, show same by dotted line on the above sketches and indicate length (/).

*Freeboard shall be the distance from the sheer line to the load waterline. The sheer line shall be taken as the intersection of the side shell with the weather deck. Where calculations require “gunwale top” to be used, the following applied: For a cockpit vessel, the gunwale top shall be measured along an imaginary extension of the sheer line in way of the cockpit. For an open boat, the gunwale top shall be considered the sheer line.

Passengers include the crew.

(5) LOCATION OF IMMERSION MARK (i) ABOVE LOAD WATERLINE PRIOR TO APPLICATION OF HEELING MOMENT:

The freeboard measurement (f) shall be taken with the weight required in Step (1) on board. The height of the immersion mark (i) shall be the lesser of the two values provided by (a), (b), (c) or (d) according to vessel type, or (e) for all vessels. The mark (i) shall be placed on the hull above the LWL at the reference station.

$$i = \underline{\hspace{10em}}$$

(a)	<p>Flush Deck Type Sailing Vessels (or well deck vessels that operate on protected waters, have non return scuppers, and the reference freeboard is not more than one quarter of the distance from the waterline to the top of the gunwale). Reference freeboard (f) is measured to the top of the weather deck at the side of the vessel.</p> $\frac{\underline{\hspace{10em}}}{\text{Reference freeboard (f)}} = \frac{\underline{\hspace{10em}}}{\text{Height of (i) above LWL}}$	
(b)	<p>Flush Deck Type Vessels (including all well deck vessels except those noted in (a) above) For well deck vessels, freeboard (f) to the lowest deck exposed to the weather must equal or exceed 25.4 cm (10 inches) If less than 25.4 cm, use 5(d) Open-boat Type formula</p> $\frac{\underline{\hspace{10em}}}{\text{Reference freeboard (f)}} / 2 = \frac{\underline{\hspace{10em}}}{\text{Height of (i) above LWL}}$	
(c)	<p style="text-align: center;">Cockpit Type Vessels</p> <p>Freeboard to cockpit deck must equal or exceed 25.4 cm (10 inches) If less than 25.4 cm, use 5 (d) Open—boat Type formula Length overall(L) Length of cockpit(/) Reference freeboard(f) (measured to top of gunwale) Height of immersion mark above LWL(i) All measurements shall be in metres (feet)</p>	<p>Exposed Waters</p> $(i) = f \left(\frac{2L - 1.5/}{4L} \right)$ <hr/> <p>Coastal or Protected Waters</p> $(i) = f \left(\frac{2L - /}{4L} \right)$
(d)	<p style="text-align: center;">Open-boat Type Vessels</p> <p>Reference freeboard (f) is measured to top of gunwale</p> $\frac{\underline{\hspace{10em}}}{\text{Reference freeboard (f)}} / 4 = \frac{\underline{\hspace{10em}}}{\text{Height of (i) above LWL}}$	
(e)	<p style="text-align: center;">All Vessel Types</p> <p>To limit the final angle of list to 14⁰ for any type of vessel, the height of the immersion mark (i) shall on no case exceed the value below. If this value is less than that produced by (a), (b), (c) or (d) above, whichever applicable, then this value shall be used for (i).</p> $\frac{\underline{\hspace{10em}}}{\text{Beam at Reference Station}} / 8 = \frac{\underline{\hspace{10em}}}{\text{Max height of (i) above LWL for any type of vessel}}$	

(7) HEIGHT OF IMMERSION MARK (I) ABOVE WATERLINE AFTER WEIGHT MOVEMENT:

$i =$ -----

- a) If the vessel lists to the immersion mark (i) before the full heeling moment is applied, the test shall be stopped and the vessel fails the test.
- b) When the moment required in Section (4) has been developed, measure the resulting height of the immersion mark (i) above the waterline.
- c) If any portlights are found to be near the waterline at the final angle of the list, such portlights on each side shall be permanently closed.
- d) If any scuppers or drains are found to be below the waterline at the final angle of list so as to permit entry of water into the or onto the deck, such openings on each side shall be fitted with automatic non-return valves.

(8) GENERAL STABILITY INFORMATION (for documentation purposes only)

Tankage

Tank	Capacity	Approximate Location of CG @ 100% Cap.	
		Aft of Stem	Above Top of Keel

Ballast:

Material	Weight	Approximate Location of CG	
		Aft of Stem	Above Top of Keel

TWENTY-FIVE PERCENT TEST

(This test is not a necessary part of the Simplified Stability Test Procedure but may be used as a preliminary Check when the stability is believed to be marginal)

1. After the Total Test Weight (W) has been placed on board and the Reference Freeboard (f) has been measured, rig a pendulum free to swing athwartships at any convenient location on the vessel. Arrange it so that the bob is approximately 3 mm (1/8 inch) above the deck. Place a chalk mark on the deck directly beneath the bob. Measure the pendulum length (pend. 1) as the distance from pivot to deck.
2. Move the test weight to obtain a heeling moment equal to one-quarter of the Required Heeling Moment in Section (4) on page 3. It is suggested that the weights having the longest levers be moved as to minimize the amount of weight handled.

One – quarter Heeling Moment: ----- /4 = ----- <div style="text-align: center;">Req'd H.M. (4)</div>

3. After the weight has been moved, place a chalk mark on the deck directly beneath the pendulum bob. Measure the pendulum deflection (pend. D.) as the distance between chalk marks.
4. Before proceeding with the Simplified Stability Test Procedure, the following calculations may be carried out to anticipate the results:

Approximate Maximum allowable Heeling Moment: $2 \times \frac{\text{-----}}{\frac{1}{4} \text{ H.M.}} \times \frac{\text{-----}}{\text{pend. 1.}} \times \frac{\text{-----}}{\text{Height of (i)}} = \text{-----}$ $\frac{\text{-----}}{\text{pend.d.}} \times \frac{\text{-----}}{\text{Beam at Ref. Station (B}_f\text{)}}$	
If the Maximum Allowable Heeling Moment is LESS than the Required Heeling Moment in Section (4) on page 3, the vessel will probably fail the test by the difference indicated below. Required Heeling Moment = ----- Allowance Heeling Moment = ----- Difference = -----	
If Passenger Heel (4a) applies Approximate Number of Passengers in Excess $6 \times \frac{\text{-----}}{\text{Difference}} = \frac{\text{-----}}{\text{\# of Pax}}$ $\frac{\text{-----}}{\text{Wt/Pax}} \times \frac{\text{-----}}{\text{(B}_p\text{)}}$	If Wind Heel (4b) applies: Approximate Excess Wind Moment (Sum A x H) $\frac{\text{-----}}{\text{Difference}} / \frac{\text{-----}}{\text{(P) Moment}} = \text{-----}$

**STABILITY TEST PROCEDURE
FOR VESSELS CARRYING PASSENGERS AND CARGO**

(1) For vessels carrying cargo as well as passengers, follow the same test procedure as for vessels carrying passengers alone except that, in addition to the passenger test weight, the maximum deadweight of cargo permitted shall be on board, in place and so arranged as to simulate the most unfavourable vertical center of gravity likely to occur in service.

(2) Specify the maximum cargo deadweight permitted to be carried:

Weight of Cargo	Approximate Location of CG	
	Aft of Stem	Above Top of Keel

(3) Complete the Twenty-Five Percent Test based on the Passenger Heeling Moment or the Wind Heeling Moment, whichever is applicable, and note the anticipated test results.

(4) If the anticipated results of the test indicates that the vessel will fail, the entire test must be repeated with a reduced number of passengers and/or a reduced amount of cargo, or by utilizing any other corrective measures available.

(5) If the anticipated results of the test indicates that the vessel will pass, then with the vessel in the heeled condition and being cautious not to disturb any of the test weights which were shifted in order to heel the vessel; remove approximately one-quarter of the cargo from the vessel exercising great care to remove it symmetrically about the centerline.

(a) If the pendulum deflection **DECREASES** or remains unchanged
-- replace the cargo which was removed and complete the stability test procedure.

(b) If the pendulum deflection **INCREASES**
-- the cargo may be improving the stability of the vessel. Therefore, remove all of the cargo from the vessel, replace the test weights in their original positions so as to remove all list, remeasure the Reference Freeboard (f), and repeat the Twenty-Five Percent Test in its entirety for the new condition of loading. If the second Twenty-Five Percent Test indicates that the vessel will pass, complete the stability test procedure.

(6) If the vessel passes the stability test procedure under these conditions, it is deemed to have adequate stability for the safe carriage of passengers allowed regardless of whether or not cargo, not in excess of the amount specified in item (2) above, is carried.

ANNEX 2(A)***STABILITY INFORMATION****(SCV Code III/Part B/5.1)***1 Sheet**

The Format of the stability booklet and the information included will vary dependent on the vessel type and operation. Units of measure used in the stability booklet must agree with the units of measure of the draft markings.

In developing the stability booklet, consideration must be given to the following information:

- .1 A general description of the vessel, including lightweight data.
- .2 Instructions on the use of the booklet.
- .3 General arrangement plans showing watertight compartments, closures, vents, downflooding angles, and allowable deck loadings.
- .4 Hydrostatic curves or tables.
- .5 Capacity plan showing capacities and vertical, longitudinal centers of gravity of stowage spaces and tanks.
- .6 Tank sounding tables showing capacities, vertical centers of gravity in graduated intervals and showing free surface data for each tank.
- .7 Information on loading restrictions, such as a maximum KG of minimum GM curve that can be used to determine compliance with applicable intact and damage stability criteria.
- .8 Examples of loading conditions.
- .9 A rapid and simple means for evaluating other loading conditions.
- .10 A brief description of the stability calculations done including assumptions.
- .11 General precautions for preventing unintentional flooding.
- .12 A table of contents and index for the booklet.
- .13 Each ship condition which, if damage occurs, may require cross-flooding for survival and information concerning the use of any special cross-flooding fittings.
- .14 The mount and location of fixed ballast.
- .15 Any other necessary guidance for the safe operation of the vessel under normal and emergency conditions.
- .16 For each self propelled hopper dredge with a working freeboard, the maximum specific gravity allowed for dredge spoil.

ANNEX 3***SMALL COMMERCIAL VESSEL SIMPLIFIED SUBDIVISION CALCULATION***

(SCV Code III/21)

Sheet 1 of 5

Name of Vessel _____	Official No. _____	Route _____
Owner or Representative Present at Measurement _____	Inspector _____	Date _____
Location of Vessel at Time of Measurement _____	No. of W.T. Bhds. _____	No. of Passengers _____

INSTRUCTIONS

1. The vessel is to be in maximum load condition except that the fuel and water tanks are to be three-quarters full. Ballast, if required, is to be on board and in place. A capacity load of passengers, crew, cargo, vehicles, stores, etc., is to be on board (or weight equivalent thereto) in proper location.
2. The vessel is to be afloat in water of a density not greater than that of the route for which she is to be certificated, i.e., salt water or fresh water.
3. The vessel is to be in her normal trim, i.e., at a waterline established by the normal distribution of the weight on board. If there is a slight list it is to be corrected by transverse movement of some of the weight on board so that the vessel is upright in the water.
4. The measurements specified on sheet 4 are to be carefully taken and recorded as indicated in steps (5) or (6) as applicable to the type of vessel. The length (L) is the length of the hull proper, measured over the bulkhead deck, and shall not include fishing platforms, bowsprits, guards, etc. The depth (D) is especially important and should be double-checked. If this particular dimension cannot be measured amidships, as required, due to obstructions, etc., it is to be made at points fore and aft of, and equidistant from amidships and the mean thereof shall be recorded as (D). The beam (B) shall be measured amidships to the outside of the hull and shall not include the guards. The freeboards (f) shall be measured at the bulkheads from the load waterline to the top of the bulkhead deck at the side. The distance from the stem to each bulkhead shall be indicated on the plan in the same manner as bulkhead "A".
5. Where the vessel has no portlights which can be opened and is flush decked with normal sheer or no sheer, record the dimensions on sheet 4 and proceed as indicated in step (7).
6. Where the vessel has portlights which can be opened, or if it is flush decked with reverse sheer, or if it has a raised deck forward (as in the case of the typical cockpit boat), do not use the sketch on sheet 4. Instead, prepare to accurate scale a profile of the hull above the load waterline, locate the bulkheads, and the portlights, if any, draw in the "corrected bulkhead deck line" as shown on sheets 2 or 3, and then proceed as indicated in step (7).

(a) **For Reverse Sheer:**

Draw a straight line from the stem (at the top of the bulkhead deck) to the stern (at the top of the bulkhead deck at the side) to establish the “corrected bulkhead deck line”.

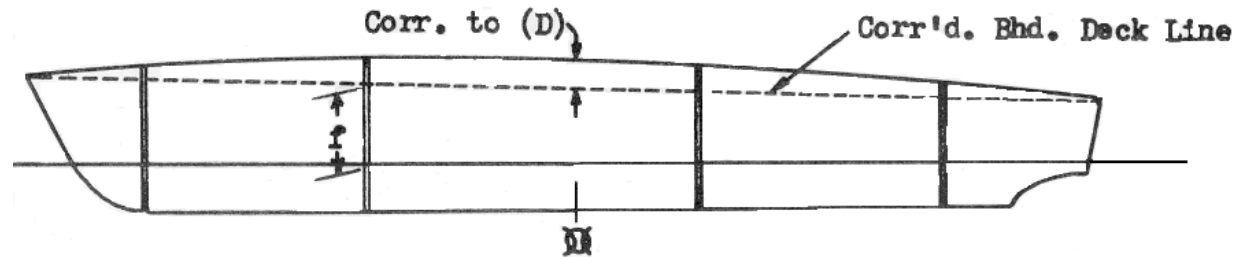

(b) **For Raised Deck:**

Draw a straight line from the bulkhead deck at the stem to the top of the foremost of the bulkheads which extend to the lower bulkhead deck, to establish the “corrected bulkhead deck line”.

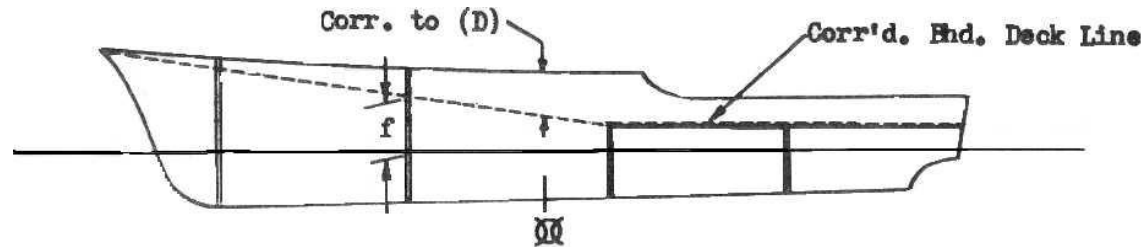

(c) **For Vessels of Any Type Having Portlights Which Open:**

The “corrected bulkhead deck line” shall be a line which extends from the stem at the actual bulkhead deck, passes not less than 75mm (3 inches) below the portlights and thence to the stern at the actual bulkhead deck. This line shall not be, at any point, above the corrected bulkhead deck line which would be indicated from the same hull if portlights were not installed.

FLUSH DECK TYPE

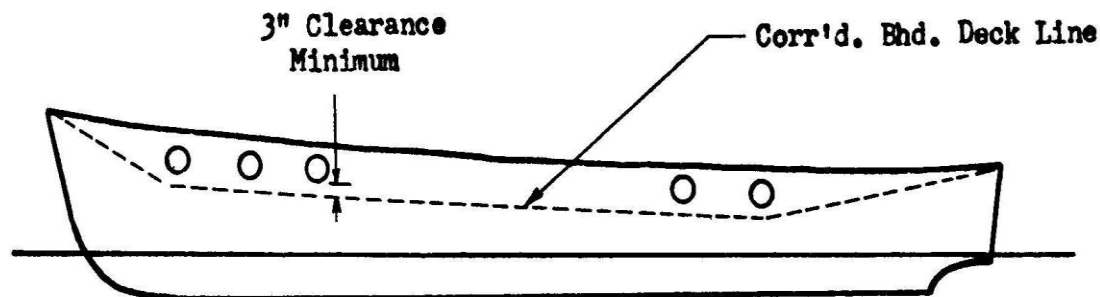

RAISED DECK TYPE:

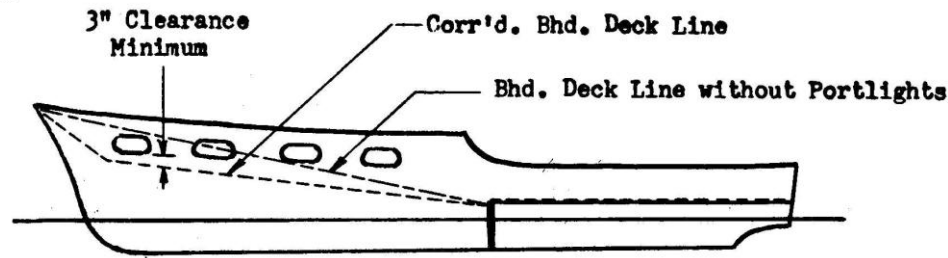

The freeboards at each bulkhead are to be scaled, on the drawing, to this corrected bulkhead deck line. Also, the distance amidships measured from this line upward to the top of the actual bulkhead deck at the side shall be deducted from the depth (D), which was measured as shown on sheet 4, to obtain the correct (D) to be used with these types of hulls.

- From the dimensions recorded on sheet 4 (or on the specially prepared profile) and the factors listed below, complete the table on sheet 5. The actual compartment lengths should not exceed the calculated permissible compartment lengths – OR – $L/3$ whichever is the least.

Midpoint of Compartment in Percent (L) from Bow	Floodable Length Factor
0-15%	.33
20	.34
25	.36
30	.38
35	.43
40	.48
45	.54
50	.61
55	.63
60	.58
65	.53
70	.48
75	.44
80	.40
85	.37
90-100	.34

Name of Vessel _____ Official No. _____

Subdivision Calculation – Sheet 4 of 5

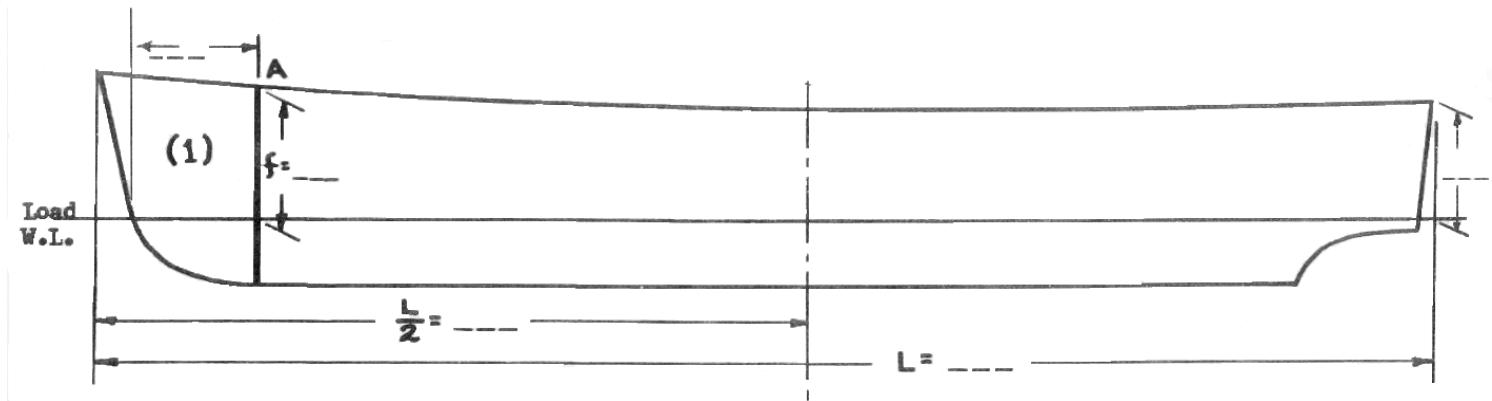

1. Draw in other W.T. bulkheads. Indicate distance from stem and freeboard for each as shown for Bulkhead "A".
2. Freeboards "x" and "y" Amidships must be equal.
3. Record all dimensions in Feet and tenths.
4. Indicate water density at time of measurement.
 Salt Brackish Fresh

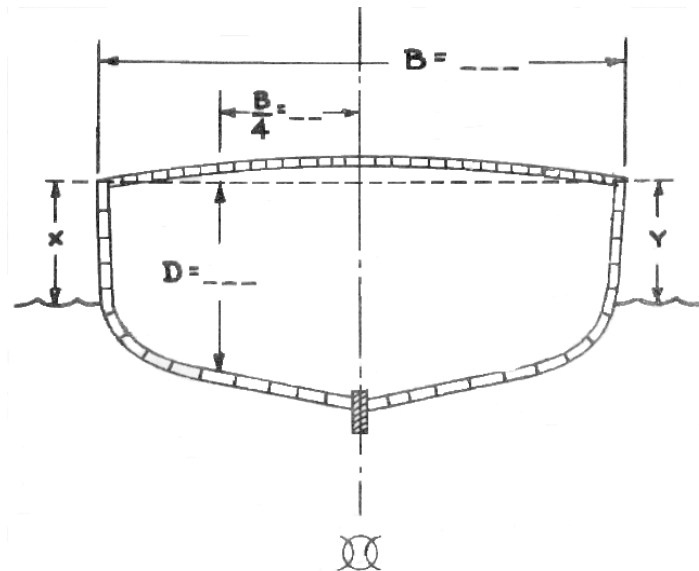

$\frac{L}{D} = \frac{\quad}{\quad} = \frac{\quad}{\quad}$

Maximum Length of Any Compartment
$\frac{L}{3} = \frac{\quad}{3} = \frac{\quad}{\quad}$

Name of Vessel _____ Official No. _____

Subdivision Calculation – Sheet 5 of 5

1	2	3	4	5	6	7	8	9	10	11
Compt. No.	Boundary Bhds.	Dist. Stem/Bhd	Dist. Stem/Bhd (as % L)	Freeboard (f)	Midpoint of Compt. (as % L)	Floodable Length Factor	Effective Freeboard	$\frac{L}{D}$	Permissible Compt. Length	Actual Compt. Length
		<i>Sheet 4</i>	<u>Col. 3x100</u> L	<i>Sheet 4</i>	Avrg. of 2 in col. 4	<i>Sheet 3</i>	Avrg. of 2 in Col. 5	<i>Sheet 4</i>	Cols. $\frac{7 \times 8 \times 9}{L/3}$ NOT to exceed m (ft)	Diff. of 2 in Col. 3
1	Stem	0	0	B					*	
	A									

Tested and Proven Watertight

*-OR- as required by SCV Code III/21.1, whichever is least.

Measured and computed by

Marine Inspector

Marine Inspector

Annex 4*(Regulation V/2.2)****FIRE TEST FOR FRP*****1 Heat Source**

The heat source for the fire tests should be provided by a propane gas torch with a Sievert burner type No. 2944 giving a maximum flame temperature of 1600C and burning propane at the rate of 4110 grams per hour with a pressure of 2kgf/cm. The rate of burning should be carefully controlled. The length of blue flame should be approximately 200mm.

2 Specimen

The specimen should be 450mm x 450mm cut from a one metre square panel of the laminate to be tested. The specimen should not incorporate any of the edges of the one metre square panel. The edges of the specimen should be housed in a steel frame sufficiently to prevent them igniting during the tests. The specimen should be cured for at least 28 days before testing.

3 Test procedure

The specimen should be oriented vertically in a draft free location, such that the tip of the blue flame, i.e. the point of greatest heat, impinges on the centre of the specimen with the flame normal to its surface. The non gel coat surface of the specimen should be exposed to the flame. The flame should not burn through the specimen within 15 minutes.

Annex 5*(Regulation V/3.2)****IGNITABILITY TEST FOR COMBUSTIBLE INSULATIONS*****1 Test Specimens**

1.1 One specimen is to be prepared.

1.2 The specimen is to be a minimum of 150mm x 150mm and of the thickness which is to be used on the vessels, together with any facing with which it is normally covered.

2 Conditioning of Test Specimens (absorbent materials)

2.1 The conditioning atmosphere should have a temperature of 20 ± 2 EC and relative humidity of 65 %.

2.2 The specimen should be laid flat, in the conditioning atmosphere for a period 24 hours, or for a sufficiently longer period in order to ensure that the mass of the specimen shows no progressive change greater than 0.25% when it is determined at intervals of 2 hours.

3 Atmosphere for Testing

3.1 The test is to be conducted in an atmosphere the same as for conditioning the specimen, or within 2 minutes of removal from the conditioning atmosphere.

3.2 Appropriate measures should be taken to prevent draughts in the vicinity of the testing equipment when testing is in progress.

4 Testing Procedure**4.1 Source of Ignition**

The source should be obtained by using a burner consisting of a copper tube having a length of 150mm and inside and outside diameters of 5mm and 6mm respectively connected by plastic or rubber tubing to a gas tap supplying natural gas. The copper tube is to have no opening for the supply of air.

4.2 Height of Flame

Before the test takes place the burner flame is to be adjusted to a height of 32mm.

4.3 Test Procedure

4.3.1 Place the specimen horizontally on a metal tripod stand with the upper surface of the specimen facing downwards (i.e. with normally exposed face on underside) such that the height of this surface of the specimen is approximately 8mm below the top of the burner flame. Apply the burner flame at right angles to the plane of the specimen in the centre of specimen. After one minute the burner flame is to be removed clear of the specimen and the time in seconds to extinction of any flaming is to be recorded.

4.3.2 The test in paragraph **4.3.1** is to be repeated after any flaming or smouldering has ceased and the temperature of the specimen has returned to normal except that the centre of the burner flame is to be positioned at the midpoint of any edge of the specimen. Again the time in seconds to extinction of any flaming after the removal of the burner is to be recorded.

5 Pass Criteria

An insulation is deemed to be “nor readily ignitable” when any flaming of the test specimen ceases within 20 seconds of the removal of the burner.

Annex 6*(Regulation VII/5.2)****RECOMMENDED EMERGENCY BROADCAST INSTRUCTIONS***

The following emergency broadcast instructions, when placed on a placard, will satisfy the requirement contained in regulation **VII/5.2** for an emergency broadcast placard:

- 1.** Make sure your radiotelephone is on.
- 2.** Select 156.8 MHz (channel 16 VHF) or 2182 kHz. (Channel 16 VHF and 2182 kHz on SSB are for emergency and calling purposes only).
- 3.** Press microphone button and, speaking slowly – clearly – calmly, say:
 - .1** “MAYDAY-MAYDAY-MAYDAY” for situations involving Immediate Danger to Life and Property;
or
 - .2** “PAN-PAN-PAN” for urgent situations where there is No Immediate Danger to Life or Property.
- 4.** Say: “THIS IS (INSERT VESSEL’S NAME), (INSERT VESSEL’S NAME), (INSERT VESSEL’S NAME), (INSERT VESSEL’S CALL SIGN), OVER.”
- 5.** Release the microphone button briefly and listen for acknowledgement. If no one answers, repeat steps **3 & 4**.
- 6.** If there is no acknowledgement, or if the Coast Guard or another vessel responds, say: “MAYDAY” OR “PAN”, (INSERT VESSEL’S NAME).”
- 7.** DESCRIBE YOUR POSITION using latitude and longitude coordinates, LORAN coordinates, or range and bearing from a known point.
- 8.** STATE THE NATURE OF THE DISTRESS.
- 9.** GIVE NUMBER OR PERSONS ABOARD AND THE NATURE OF ANY INJURIES.
- 10.** ESTIMATE THE PRESENT SEAWORTHINESS OF YOUR VESSEL.
- 11.** BRIEFLY DESCRIBE YOUR VESSEL: (INSERT LENGTH, COLOR, HULL TYPE, TRIM, MASTS, POWER, AND ADDITIONAL DISTINGUISHING FEATURES).
- 12.** Say: “I WILL BE LISTENING ON CHANNEL 16/2182.”
- 13.** End message by saying: “THIS IS (INSERT VESSEL’S NAME & CALL SIGN).”
- 14.** Where your situation permits stand by the radio to await further communications with the Coast Guard or another vessel. If no answer, repeat, then try another channel.

Annex 7

(Regulation VII/7.1)

ANCHORS AND CABLES

$\frac{\text{Length} + \text{Lwl}}{2}$	Anchor Mass		Anchor Cable Diameter			
	Main	Kedge	Main		Kedge	
(metres)	(kg)	(kg)	Chain (mm)	Rope (mm)	Chain (mm)	Rope (mm)
6	8	4	6	12	6	10
7	9	4	8	12	6	10
8	10	5	8	12	6	10
9	11	5	8	12	6	10
10	13	6	8	12	6	10
11	15	7	8	12	6	10
12	18	9	8	14	8	12
13	21	10	10	14	8	12
14	24	12	10	14	8	12
15	27	13	10	-	8	12
16	30	15	10	-	8	12
17	34	17	10	-	8	14
18	38	19	10	-	8	14
19	42	21	12	-	10	14
20	47	23	12	-	10	14
21	52	26	12	-	10	14
22	57	28	12	-	10	16
23	62	31	12	-	10	16
24	68	34	12	-	10	16

Notes:

- The anchor sizes given are for high holding power (HHP) types.
- When a vessel has unusually high windage due to any combination of high free-board, large superstructure or deck equipment outfit, the mass of anchor given above shall be increased to take account of the increase in wind loading.
For vessels of unusual or non-conventional ship form (including pontoon barges) the anchor size shall be to the satisfaction of the Administration.
The diameter of the anchor cable shall be appropriate to the increased mass of anchor.
- Chain cable diameter given is for short link chain. Chain cable should be sized in accordance with ISO 4565:1986 - Anchor chains for small craft, or equivalent.
- The rope diameter given is for nylon construction. When rope of another construction is proposed, the breaking load should be not less than that of the nylon rope specified in the table.
- When anchors and cables are manufactured to imperial sizes, the metric equivalent of the anchor mass and the cable diameter shall not be less than the table value.
- Lwl is the waterline length of the vessel when the vessel is floating at the assigned free-board draught.

Annex 8*(Regulation VII/8.2)***FIRST AID KITS****1 Type and Size**

First-aid kits shall be of the water-tight cabinet carrying type capable of holding the items specified in paragraph 3.2.

2 Construction and Workmanship

The container shall be of substantial and rugged construction, with the body, handle and all fittings of a corrosion-resistant material or suitably protected against corrosion to the satisfaction of the Administration.

3 Contents

3.1 Items shall be properly labelled to designate the name of contents and method of use. Each package shall be enclosed in a jacket of tough, transparent material, properly sealed, which shall be watertight. Vials for tablets shall not be made of glass.

3.2 The items contained in the first-aid kit shall be as listed in the following Table.

TABLE A8

Items	No.
Bandage compress - 4"	5
Bandage compress - 2"	8
Waterproof adhesive compress - 1"	32
Triangular bandage - 40"	3
Eye dressing packet, 1/8 oz Ophthalmic ointment, adhesive strips, cotton pads	3
Bandage, gauze, compressed, 2 inches by 6 yards	2
1 - Tourniquet, 1 - forceps, 1 - scissors, 12 safety pins	-
Wire splint	1
Ammonia inhalants	10
Iodine applicators (½ ml swab type)	10
Aspirin, phenacetin and caffeine compound, 6½ gr. tablets, vials of 20	5
Sterile petrolatum gauze, 3" x 18"	12

3.3 Instructions

Instructions for the use of the contents of the first-aid kit shall be printed in legible type on a durable surface and shall be securely attached to the inside of the cover. The instructions for the use of the contents are as follows:-

DIRECTIONS FOR THE USE OF THE FIRST-AID KIT

Item Title	Remarks
Ammonia inhalants	Break one and inhale for faintness, fainting, or collapse.
Aspirin, phenacetin, caffeine tablets	Chew up and swallow 2 tablets every three hours for headache, colds, minor aches, pains, and fever. Maximum of 8 in twenty-four hours.
Bandage compress, 4" and 2"	Apply as a dressing over wound. DO NOT touch part that comes in contact with wound.
Bandage, gauze, compressed, 2"	For securing splints, dressings, etc.
Bandage, triangular, compressed	Use as arm sling, tourniquet, or for retaining splints or dressings in place.
Burn dressing	The petrolatum gauze bandage is applied in at least two layers over the burned surface and an area extending 2" beyond it. The first dressing should be allowed to remain in place, changing only the outer, dry bandage as needed, for at least 10 days unless signs of infection develop after several days, in which case the dressing should be removed and the burn treated as an infected wound. Watch for blueness or coldness of the skin beyond the dressing and loosen the dressing if they appear.
Compress, adhesive, 1"	Apply as dressing over small wounds. DO NOT touch part that comes in contact with wound.
Eye patch	Apply as dressing over inflamed or injured eye.
Forceps	Use to remove splinters or foreign bodies. Do not dig.
Ophthalmic ointment	Apply in space formed by pulling lower eyelid down, once daily for inflamed or injured eyes. Do not touch eyeball with tube.
Splint, wire	Pad with gauze and mold to member to immobilize broken bones. Hold in place with bandage. Do not attempt to set the bone.
Tincture of iodine, mild	Remove protective sleeve, crush tube and apply swab end. DO NOT use in or around eyes.
Tourniquet	For control of hemorrhage. Loosen for a few seconds every 15 minutes.

4 Marking

Each approved first-aid kit shall be permanently marked with the following information: name of manufacturer, trade name symbol, model number, or other identification used by the manufacturer and the words "FIRST-AID KIT".

Annex 9*(Regulation VII/10.3)***ESTIMATING GUIDELINES FOR HOLDING TANK CAPACITY**

1 These calculations shall be used as guidelines, as capacities are not mandated. The capacity of each Marine Sanitation Device (MSD) should be evaluated in terms of the vessel's size, route, service, and particular circumstances. These capacities consider only "black-water" toilet drains. On the average, each person will produce 0.4 gallons of waste per day.

2 Flush Rate. **Table A9-1** estimates the water used per flush by different toilet systems.

TABLE A9-1**APPROXIMATE FLUSH CAPACITIES FOR VESSEL TOILETS
DRAINING TO MARINE SANITATION DEVICES**

System Type	Gallons per flush
Conventional (flushometer)	5.0
Recirculating	0.1
Vacuum	0.3
Hand Pump	0.5
Electric Pump	1.0

3 Wastewater produced. **Table A9-2** estimates the gallons of wastewater produced per person per day, based on the plumbing type, and the way the boat operates.

TABLE A9-2**GALLONS OF WASTEWATER PER PERSON
PER DAY BASED ON PLUMBING TYPE**

Trip Length	User	Conv.	Recirc.	Vacuum	Band Pump	Electric
LONG (Note 1)	Crew	25.4	0.5	1.9	2.9	5.4
	Pax	25.4	0.5	1.9	2.9	5.4
MEDIUM (Note 2)	Crew	25.4	0.5	1.9	2.9	5.4
	Pax	8.3	0.17	1.9	1.0	1.8
SHORT (Note 3)	Crew	12.7	0.25	0.95	1.95	2.7
	Pax	6.35	0.25	0.5	0.7	1.35

Note

- 1** Crew and passengers aboard 24 hour/day.
- 2** Crew aboard 24-hour/day; 2 groups of passengers aboard for 4 hours each (2 trips/day), each passenger using facilities once.
- 3** All crew aboard 12 hour/day; 6 groups of passengers aboard for 2 hours (6 trips per day), one fourth of passengers using facilities once.

Annex 10

(Regulation IX/3.1)

FORM OF BOATMASTER AND BOAT ENGINEER LICENCE

COAT
OF
ARMS

BOATMASTER LICENCE GRADE 1/2/3
Issued by the
[ADMINISTRATION]
under the provisions of the
Code of Safety for Small Commercial Vessels

PHOTOGRAPH

No.....

This is to certify that
is entitled to serve in a capacity requiring a Boatmaster Grade 1/2/3 in commercial vessels of metres
in length operating in *Protected/Coastal/Exposed* waters.

The holder is further entitled to serve in such other vessels and in such areas as may be endorsed on this certificate.
ENDORSEMENT:

Date of Issue:

Date of Expiry:

.....
Signature of Holder

OFFICIAL
STAMP

.....
Director of [Maritime Affairs]

This Licence is valid only if the holder is in possession of a valid medical fitness certificate

COAT
OF
ARMS

BOAT ENGINEER LICENCE GRADE 1/2
issued by the
[ADMINISTRATION]
under the provisions of the
Code of Safety for Small Commercial Vessels

PHOTOGRAPH

No.....

This is to certify that
is entitled to serve in a capacity requiring a Boat Engineer Grade 1/2 in commercial vessels with an installed power of
less than 750 kW operating in *Coastal/ Exposed* waters.

The holder is further entitled to serve in such other vessels and in such areas as may be endorsed on this certificate.
ENDORSEMENT:

Date of Issue:

Date of Expiry:

.....
Signature of Holder

OFFICIAL
STAMP

.....
Director of [Maritime Affairs]

This Licence is valid only if the holder is in possession of a valid medical fitness certificate

Annex 11*(Regulation IX/4.3)***SYLLABUS FOR BOATMASTER AND BOAT ENGINEER LICENCES****1. BOATMASTER LICENCE SYLLABUS****1.1 Syllabus Requirements**

The syllabus below will be modified by the Examiner to take into account the equipment on board the vessel.

For instance, it is unlikely that open boat vessels operating solely in bays or harbours will be provided with a compass and an applicant would not be examined in this subject.

Syllabus Content	Grade		
	3	2	1
A. PRACTICAL TEST (This test should take place on a vessel of a type for which the applicant is requiring a licence).			
Boat Handling:			
Berthing and unberthing	Y	Y	Y
Coming to and weighing anchor	Y	Y	Y
Making fast to and leaving a buoy	Y	Y	Y
Boat manoeuvring in confined waters	Y	Y	Y
Turning short round	Y	Y	Y
Knowledge and effect of transverse thrust	Y	Y	Y
Steering a compass course and taking a rough bearing	Y	Y	Y
Practical demonstration on the use of VHF on board the applicant's vessel. The holder must have knowledge of procedures used in radio telephone (VHF and MF) communications particularly with respect to distress, urgency, safety and navigational messages and of the adverse effect of misuse of such equipment	Y	Y	Y

Syllabus Content	Grade		
	3	2	1
B. ORAL EXAMINATION			
B1. Emergency Situations:			
Recovery of man overboard	Y	Y	Y
Loss of engines	Y	Y	Y
Loss of steering ability	Y	Y	Y
Action to take in the event of collision	Y	Y	Y
Grounding	Y	Y	Y
Accident to crew member or passenger	Y	Y	Y
Use of extinguishing appliances	Y	Y	Y
Use of lifesaving appliances	Y	Y	Y
Search and rescue techniques in bad weather or reduced visibility		Y	Y
Choosing an appropriate area for beaching		Y	Y
B2. REGULATIONS FOR PREVENTING COLLISION AT SEA:			
A practical knowledge of the Rule of the Road as appropriate to the area of operation	Y	Y	Y
A full knowledge of the regulations		Y	Y
Keeping a good lookout	Y	Y	Y
Keeping of a Deck Log		Y	Y
B3. LOCAL KNOWLEDGE AND REGULATIONS:			
Actions to be taken in the event of injury or loss of life to a crew member		Y	Y
Certification required by the vessel		Y	Y
Limits as to vessel operation	Y	Y	Y
B4. SEAMANSHIP:			
Common nautical terms	Y	Y	Y
Interaction with other vessels	Y	Y	Y
The effect of wind and tide on the manoeuvrability	Y	Y	Y
Securing and stowage of anchors and cable		Y	Y
Selection of a proper anchorage		Y	Y
The importance of navigating at reduced speed to avoid damage caused by own vessels bow or stern wave	Y	Y	Y
The difference in handling of single screw and twin screw boats		Y	Y
B5. CHARTWORK:			
The meaning of common chart symbols		Y	Y

Syllabus Content	Grade		
	3	2	1
The use of Tidal Diamonds		Y	Y
Position fixing			Y
Courses to steer allowing for current and leeway			Y
Familiarity with the use of parallel rules, dividers, compasses, etc.			Y
B6. LIFE-SAVING AND FIRE-FIGHTING APPLIANCES:			
A knowledge of the statutory requirements and appreciation of the fact that the person in charge of a vessel must be satisfied that the life-saving and fire-fighting appliances are properly maintained		Y	Y
Use and deployment of inflatable liferafts and inflatable or rescue boats			Y
Inflatable liferaft and boat servicing requirements			Y
Hydrostatic release units			Y
Maintenance and care of buoyant apparatus		Y	Y
B7. DISTRESS SIGNALS:			
A knowledge of the contents of Annex IV of the Collision Regulations and the operation of the signals and equipment required to be carried in the applicant's vessel		Y	Y
Coast Guard response to distress signals		Y	Y
B8. PASSENGER SAFETY:			
Safety announcements (<i>See regulation VIII/6</i>)	Y	Y	Y
Disposition of passengers and crew to ensure stability and trim	Y	Y	Y
Passenger numbers and reporting systems (<i>See regulation VIII/5</i>)	Y	Y	Y
Knowledge of emergency instructions (<i>See regulation VIII/8</i>) and methods of orderly evacuation following any emergency, having regard to the size of the vessel concerned and its operational area		Y	Y
Ability to demonstrate to passengers the use of personal lifesaving appliances	Y	Y	Y
B9. LEGAL RESPONSIBILITIES TOWARDS PASSENGERS AND CREW:			
Safe access	Y	Y	Y
Safe working practices	Y	Y	Y
Certificate of Inspection and regulations relating thereto (<i>See regulation 12</i>)	Y	Y	Y
B10. WEATHER:			
Sources of information	Y	Y	Y
Local conditions and effects	Y	Y	Y
Signs of approaching bad weather	Y	Y	Y
B11. ENGINEERING KNOWLEDGE:			
Basic knowledge of day to day engine and battery checks	Y	Y	Y

Syllabus Content	Grade		
	3	2	1
Knowledge of the servicing and routine maintenance of propulsion and auxiliary machinery	Y	Y	Y
Knowledge of safety and shut off devices			
Basic knowledge of running checks	Y	Y	Y
Methods of fault detection, correction and emergency repairs	Y	Y	Y
B12. PUBLICATIONS:			
Merchant Shipping Notices (as applicable)			Y
Regulations (as applicable)			Y
B13. PREVENTION OF POLLUTION:			
A general appreciation of the Regulations applicable to the prevention of pollution			Y
The trainee must be able to make proper use of a weather report given by radio or television forecaster			
Knowledge of the factors contributing to and precautions to be observed to prevent marine pollution when pumping out bilges and particularly, when changing lubricating oil		Y	Y
Knowledge that disposal into the sea of all plastics, including but not limited to synthetic ropes, plastic sheeting and garbage bags etc., is prohibited	Y	Y	Y
B14. ELECTRONIC AIDS TO NAVIGATION:			
Knowledge of the use of Radar, Echo Sounder and Satellite Navigation or other position-finding device fitted on board the applicant's vessel		Y	Y
B15. BASIC KNOWLEDGE OF VESSEL CONSTRUCTION AND STABILITY:			
General ideas on ship construction and on plans available on board the vessel, where these are carried			Y
Maintaining watertight sub-division			Y
General pumping arrangements			Y
General principles of workboat stability			Y
Heeling forces and their causes			Y
Wind Pressure on projected areas			Y
Application and effects of asymmetric loading			Y
Overtight mooring			Y
Equilibrium in the heeled condition			Y
Simple dynamic balance			Y
Effect of liquid free surface and its control			Y
Cranes, their operation and safe operating limits			Y
Outline knowledge of freeboard and trim			Y
The use of stability and hydrostatic data where provided			Y
Knowledge of the effect of severe wind and rolling in associated sea conditions, especially in following seas		Y	Y

1.2 Additional Qualifications

.1 Basic Safety Training Course

- .1 Basic Sea Survival - IMO Model Course 1.19.
- .2 Elementary First Aid - IMO Model Course 1.1.3
- .3 Basic Firefighting Course - IMO Model Course 1.20.
- .4 Personal Safety and Social Responsibility - IMO Model Course 1.21.

- .2 VHF Certificate: Every person in charge of a vessel which has a VHF set on board shall be the holder of a VHF Radiotelephone Operator licence.

1.3 Practical Sail Boat Test

This test is to take place on a vessel of a size for which the applicant is licenced.

- .1 Getting the boat away from a pier or wharf.
- .2 Bring the boat alongside a pier or wharf.
- .2a Securing to a pier or wharf.
- .3 Manoeuvring the boat to pick up a man overboard.
- .4 Manoeuvring the boat to pick up a mooring buoy or marker.
- .5 Be able to change tack.
- .6 Be able to sail to all points of the wind.
- .7 Anchoring and retrieving anchor.

2. BOAT ENGINEER SYLLABUS

2.1 Emergencies

The following are some of which the candidate must be knowledgeable.

- .1 Assessment of damage and damage control
- .2 Temporary plugging of leaks
- .3 Man overboard procedure
- .4 Fire in the engine compartment
- .5 Action to be taken in the event of ingress of seawater into the engine compartment
- .6 Procedure to be followed in the event of partial or total electrical failure
- .7 Isolation of main engine units in the event of malfunction and the action necessary to continue safe operation.
- .8 Action to be taken when abandoning the vessel

2.2 Operating Procedure

The candidate should have knowledge in the following -

- .1 Method of preparation of various systems and checks prior to starting which should include -
 - .1 Machinery
 - .2 Clutches
 - .3 Stern tube
 - .4 Propeller
 - .5 Steering gear
 - .6 Sump level
 - .7 Filters
 - .8 Fuel system
 - .9 Safety equipment
- .2 Checks during running to include
 - .1 Machinery
 - .2 Stern tube
 - .3 Steering gear
 - .4 Sump levels
 - .5 Filters
- .3 Methods of fault detection, correction and emergency repairs
- .4 Precautions to ensure that machinery is not damaged due to misuse through overspeeding overloading, lack of lubrication or by corrosion.

2.3 Prevention of Marine Pollution:

The candidate should have knowledge of the following:

- .1 Regulations applicable to the prevention of pollution (a general appreciation.
- .2 Factors contributing to and precautions to be observed to prevent marine pollution when pumping out bilges and particularly, when changing lubricating oil
- .3 that disposal into the sea of all plastics, including but not limited to synthetic ropes, plastic sheeting and garbage bags etc., is prohibited

2.4 Marine Engines

The candidate should have a thorough knowledge in the following areas

- .1 Working principles of marine engines
 - .1 Two stroke and four stroke cycles
 - .2 Piston position, valve positions, timing etc.
- .2 Comparison between diesel and petrol engines
 - .1 Engine capacity
 - .2 Bore

- .3 Difference between compression and electric spark ignition
- .4 Fuel injection systems
- .5 The weight of the engine block

- .3 Air and exhaust systems**
 - .1 Air fitters, manifolds, exhaust pipes and silences
 - .2 Use of pumps and blowers
 - .3 Supercharging and its effects on the engine

- .4 Fuel systems**
 - .1 Types of fuel
 - .2 Storage and transfer systems
 - .3 Effects of dirt and water contamination
 - .4 Fitters, separators, pumps, carburetors and fuel injection systems.
 - .5 The combustion and ignition process

- .5 Cooling systems**
 - .1 Mediums of cooling
 - .2 Heat exchanges
 - .3 Radiators
 - .4 Control of overheating
 - .5 Advantages and disadvantages of various cooling systems
 - .6 Corrosion and use of sacrificial anodes

- .6 Lubrication Systems**
 - .1 Principles and purposes of lubrication
 - .2 Types of bearings and their fitting, care, maintenance and adjustment
 - .3 Types and grading of lubricating oils
 - .4 Use of grease
 - .5 Sea water contamination and procedures after contamination

- .7 Starting Systems**
 - .1 Hand recoil
 - .2 Electric
 - .3 Compressed air

2.5 Electrical Systems

The candidate should have knowledge of the following areas

- .1 General construction, care and maintenance of alternating and direct current generators
- .2 Switch boards and shipboard circuitry
- .3 Starters and their care and maintenance
- .4 Batteries and their care and maintenance
- .5 Operating precautions and dangers of explosion short circuits etc.

2.6 Pumps and Pumping Systems

The candidate should have knowledge of the following areas

- .1 Construction, care and maintenance of all types of pumps used on vessels
- .2 Causes of loss of output, methods of priming and maintenance of priming devices
- .3 Arrangement of bilge water pumping systems
- .4 Types of valve chests
- .5 Causes of deterioration and leakage and its temporary and permanent repairs
- .6 Procedure for getting rid of oily bilgewater.

2.7 Propulsion Systems

The candidate should have knowledge of the following

- .1 Stern tube
 - .1 Stern tube bearings
 - .2 Stern glands and packing
- .2 Clutches and gear boxes
- .3 Shafting
 - .1 Intermediate shafts
 - .2 Types of bearings
 - .3 Types of shafts
 - .4 Shaft alignment checking and correction of misalignment.
- .4 Damage to and repair of propellers
- .5 Typical steering gear arrangement including mechanical, hydraulic and electro hydraulic, emergency procedures, care and maintenance.

2.8 Safe - Working Procedures

The candidate should have knowledge of the following -

- .1 The use of instruction manuals which should be understood and clearly followed for both the operation and maintenance of the machinery.
- .2 The effective use of safety guards in way of all hot parts and moving parts for the safety of personnel.
- .3 Safety and shut off devices associated with fuel oil and lubricating oil systems.
- .4 The use of adequate protective equipment and clothing.
- .5 Safe use and care of all tools
- .6 Safe use of all lifting devices
- .7 Display of warning signs.

2.9 Auxiliary Machinery and Systems

The candidate should have knowledge in the following -

- .1 Air Compressors

The general arrangement of single and multi stage compressors, their care maintenance and emergency repairs.
- .2 Hydraulic Systems

Basic principles of power hydraulics, hydraulic fluid systems for winches, steering gear etc, fault finding care and maintenance.
- .3 Electrotechnology
 - .1 General principles of electricity - voltage, current, resistance
 - .2 Basic principles of alternating and direct current
 - .3 Effects of electric current; conductors and insulators; lamps; cable and fuses.
 - .4 The construction, capacity, care and maintenance of batteries.
- .4 Deck Machinery

Winches and windlass, types, method of operation and maintenance.

2.10 Outboard Engines

The candidate should have knowledge of the following -

- .1 Principles of two and four stroke engines and related valve and crank position.
- .2 The purpose and working of -
 - .1 Flywheel
 - .2 Valves and scavenging
 - .3 Fuel system
 - .4 Ignition system
 - .5 Transmission
 - .6 Gear box
 - .7 Lubrication
 - .8 Cooling
 - .9 Starting
- .3 Trouble identification
 - .1 Starting difficulties
 - .2 Running difficulties
 - .3 Importance of replacement shear pins

.4 Servicing and Maintenance

- .1 Inspection procedures
- .2 Carburetor maintenance
- .3 Engine mounting
- .4 Procedures for lay up or storage.